

# Span Linear Suspension

LED T20

## DESCRIPTION

The Span Linear by Tech Lighting is an ultra-thin architectural fixture that utilizes a backbone of edge-lit guide technology. Appearing as a silhouetted plate of frosted glass when off then illuminates across the entire surface as if the light is coming out of thin air. This ultra-modern linear fixture is available in two on-trend finishes, Satin Nickel and Matte Black. The Span Linear scales at 4.5" in height and 46.2" width making it ideal for dining room lighting, conference room lighting and hospitality lighting applications. The integrated LED lamp is fully dimmable to create the desired ambiance using a low-voltage ELV or Triac dimmer. Includes 76 watt, 3170 delivered lumens, 3000K, 90 CRI LED linear modules. Dimmable with low-voltage electronic dimmer. Ships with twelve feet field cuttable cable.

## INSTALLATION

This product can mount to either a 4" square electrical box with round plaster ring or an octagonal electrical box (not included).

## WEIGHT

9.0-9.5lb / 4.08-4.31kg ±

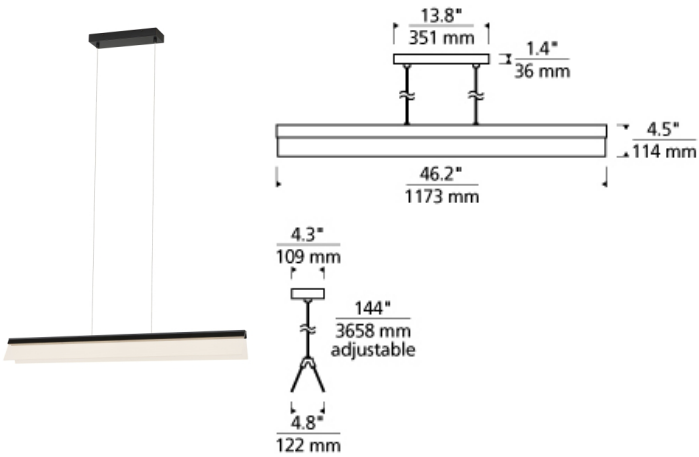

## ORDERING INFORMATION

700LSSPAN48 FINISH

LAMP

B BLACK  
S SATIN NICKEL

-LED930 LED 90 CRI 3000K 120V  
-LED930-277 LED 90 CRI 3000K 277V



700LS SPAN48

FIXTURE: \_\_\_\_\_

TYPE: \_\_\_\_\_

JOB NAME: \_\_\_\_\_

NOTES: \_\_\_\_\_



©2019 Tech Lighting, L.L.C. All Rights Reserved. The "Tech Lighting" graphic is a registered trademark of Tech Lighting, L.L.C. Tech Lighting reserves the right to change specifications for product improvements without notification.