

ENG WARNING – RISK OF FIRE AND ELECTRIC SHOCK. THIS PRODUCT IS BEST INSTALLED BY A QUALIFIED ELECTRICIAN.
INSTALL IN ACCORDANCE WITH CURRENT NEC WIRING REGULATIONS.

SUITABLE FOR DRY LOCATIONS ONLY

THE FITTING MUST BE GROUNDED. TURN OFF POWER AT THE MAIN FUSE BEFORE COMMENCING INSTALLATION.

FR ATTENTION – RISQUE D'INCENDIE, RISQUE DE CHOC.

CE PRODUIT DOIT ÊTRE INSTALLÉ SELON LE CODE D'INSTALLATION PERTINENT, PAR UNE PERSONNE QUI CONNAÎT BIEN LE PRODUIT ET SON FONCTIONNEMENT AINSI QUE LES RISQUES INHÉRENTS.

POUR EMPLACEMENTS SECS SEULEMENT

L'APPAREIL DOIT ÊTRE MIS À LA TERRE. COUPEZ LE FUSIBLE PRINCIPAL AVANT DE COMMENCER L'INSTALLATION.

- 1 Ensure that the electrical supply is OFF. Disconnect the electrical supply at the fuse-board.
- 2 If removing an existing fitting first, note all wiring connections: record which of the house wires is connected to the live (hot), neutral and earth (ground) terminals.
- 3 Carefully identify where the supply cable is (and check there are no other cables in the area) to avoid damage to concealed wiring during installation.
- 4 Position the light where desired ensuring that there is access to a suitable junction box for the fixture and suitable support adjacent to where you will connect to the house supply and mark position of fixing holes, before drilling appropriate holes as below.
 - a. Brick or masonry: Drill holes into which the wall plugs tightly fit, then insert wall plugs.
 - b. Wood: No hole necessary (unless small pilot hole required), screws can be screwed directly into the timber.
 - c. Plaster/Cavity: Special cavity wall fittings are required, rather than provided fixings.
- 5 Open your existing junction box (if you do not have one in the desired position you will need to get an electrician to install one). In your junction box there should be two supply wires and one ground wire. Connect your new lamp to the electrical supply using UL approved wire nuts. Connect the live (hot) black wire from the power supply to the black conductor on the luminaire cable, then the white (neutral) wire to the white conductor on the luminaire cable and bare copper or green/yellow ground wire to the ground terminal or green/yellow wire connected to the fitting.

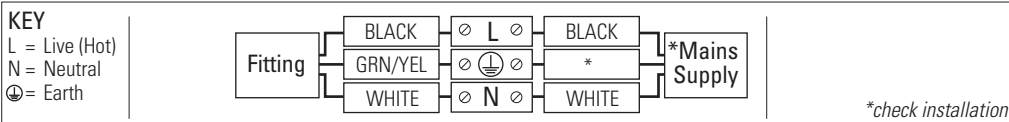

- 6 Support the fitting so that no strain is applied to the wiring when making the electrical connections.
- 7 Double check all the connections are secure, no wires are trapped behind or within the fitting and complete the installation, screwing the fitting to the wall, over your junction box.
- 8 Fit the correct type and wattage of bulb, referring to guidance inside. Do not overtighten bulb.
- 9 Switch on at the fuse-board. Your light fitting is now ready for use.

Other Important Information

Switch off at mains before changing lamp(s). Never fit a lamp of greater wattage than recommended. Ensure children do not play with the light fitting. Dispose of old lamps carefully. Never leave a fitting without a lamp in position (or someone can accidentally touch the contacts). If the electrical flex or electrical components become damaged at any point, power to the fitting should be disconnected immediately and not operated until the damaged parts are fixed/replaced.

Cleaning and Maintenance

Metal finishes should only be cleaned with a soft, dry cloth. Do not use polishes or abrasives. Switch off power to the fitting before cleaning.

Established in 1990, Original BTC manufactures relaxed, familiar lighting for traditional and contemporary homes. All products are hand-assembled in Oxford from high quality components, produced in the UK.

ORIGINALBTC.COM
 +44 (0)1993 882 251
 UNIT 21 / 22 AVENUE ONE, STATION LANE, WITNEY, OX28 4XZ, ENGLAND

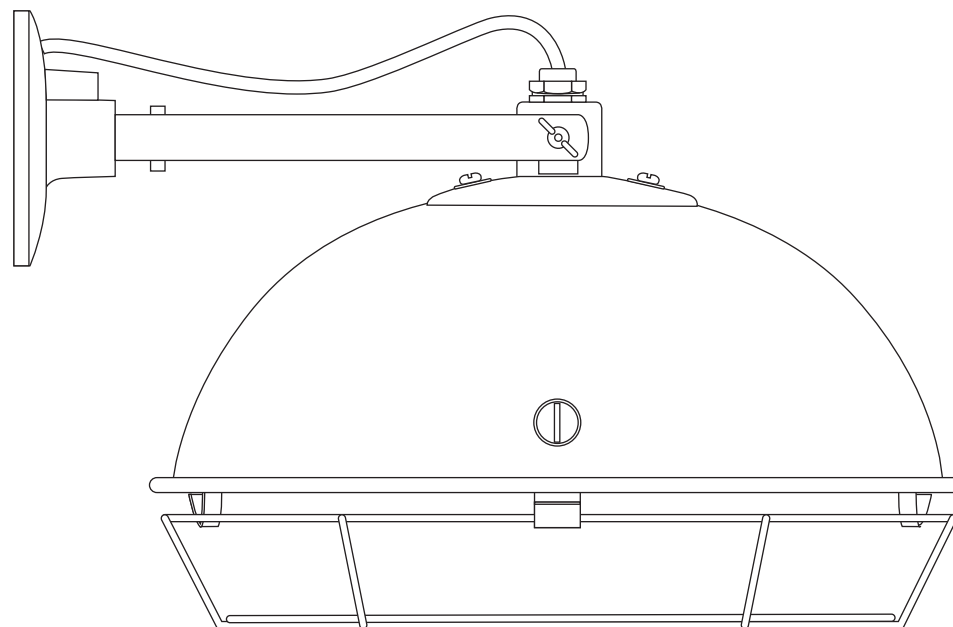

US-DP7238/US-DP7242 BRKT

| 120V ac 60Hz | IP20

Installation Diagram

LAMP GUIDANCE

MODEL	TYPE	WATTAGE
US-DP7238/BRKT	1 x E26	1 x 100W
US-DP7242/BRKT	1 x E26	1 x 100W
US-DP7242/GA/6E26/BRKT	6 x E26	6 x 40W

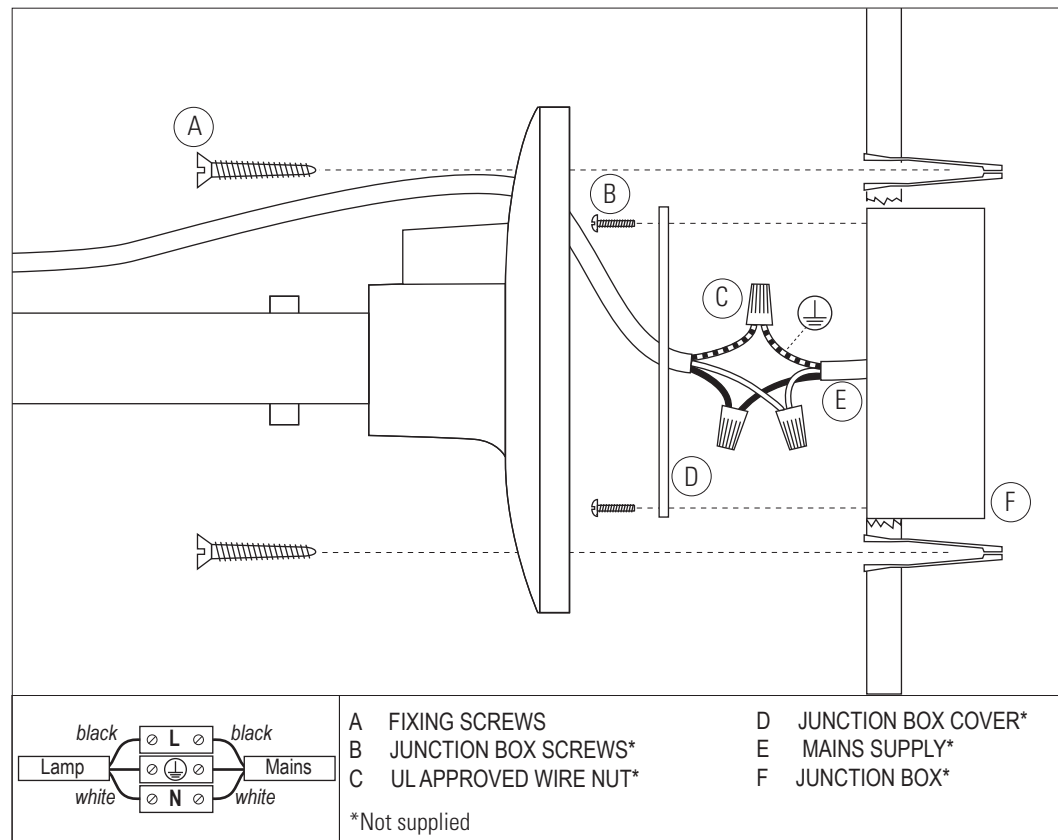
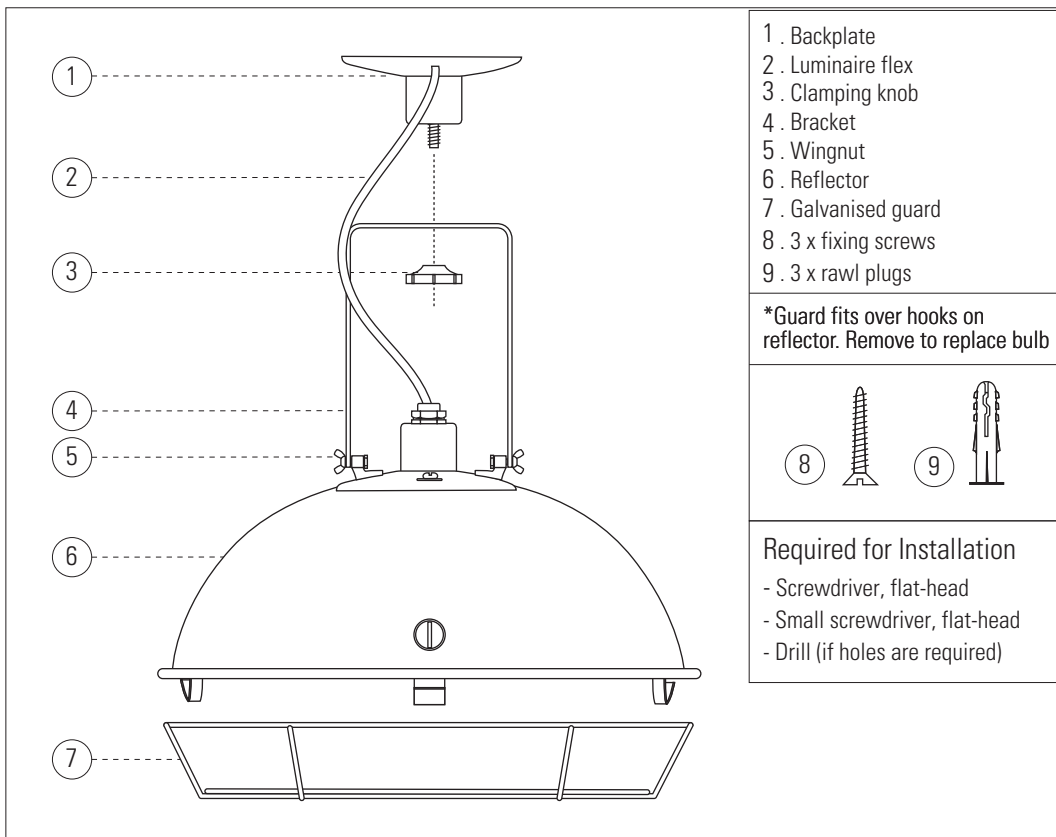

PLEASE READ THE INSTRUCTIONS ON THE REVERSE BEFORE YOU BEGIN INSTALLING YOUR LIGHT

Installation and Assembly Instructions

Follow the instructions overleaf to install the fitting. Insert the bulb(s) before installing the galvanised wire guard over the hooks on the reflector.

The angle of the shade and the bracket can be adjusted by positioning the shade and the bracket as desired, before tightening the wingnuts/clamping knob to hold the position.