

Product Description

The light is fixed through an aperture in the bead head board which is held in place by a nut, secured from the back of the bed head. The light features a flexible stem to allow it to be positioned as required.

Metal finish

The light comes in the following metal finishes:

- Clear Anodised Aluminium
- Anodised Titanium
- Anodised Bronze
- Polished Nickel Plate
- Gold Plate

Leather finish

The light comes in the following leather finishes:

- Chocolate
- Beige
- Black
- Mushroom
- Off White

Dimensions

Depth/18.03"
Bracket Depth/1.46"
Cable Length/19.68"

Electrical

The light uses 1.68 Watts of energy and requires a 12v DC power Supply.

The Cirrus light is available in the following switching mode and LED colours.

- Warm White/High, Medium, Off
- Cool White/High, Medium, Off

Additional information

The Jetstream Through the Bed light requires a driver for installing on a Mains voltage circuit. This driver should be installed remotely in a suitable area behind the fitting.



Tel: 01993 868866
Web: www.beadlight.com
Email: contact@beadlight.com

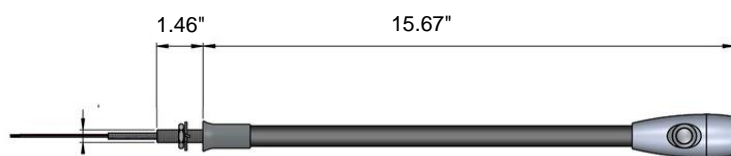
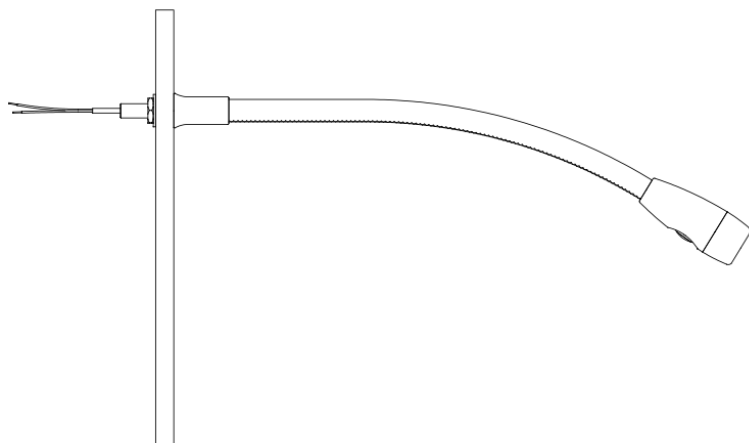

Light
Dimensions in inches

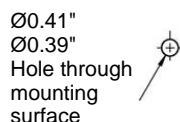

MOUNTING HOLE
Dimensions in inches

Jetstream Range/ Installation Instruction

Installation Preparation

Note: This light requires a power supply do not connect it directly to mains.

Installation should only be carried out by a person who is capable and conversant with the current regulations regarding electrical installations in the country the light is being installed.

Please ensure the circuit which the light will be attached is installed and fused correctly according to the countries current regulations.

Ensure that electrical supply is off. Turn the supply off from the distribution board and ensure it can't be inadvertently turned back on.

Identify where the supply cable runs and any other wiring in the wall before deciding on a mounting position for the lamp to ensure no damage occurs to concealed wiring during installation.

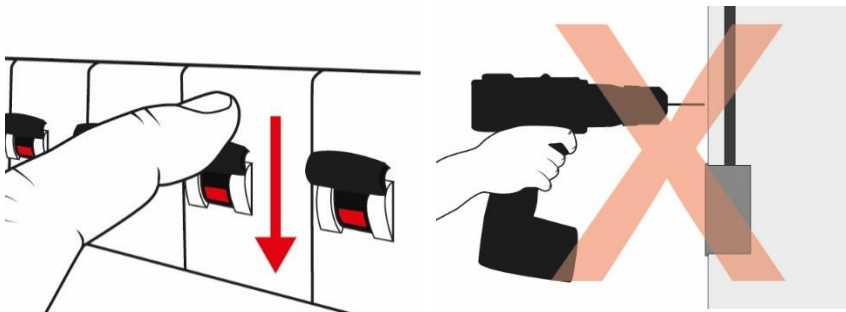

It is of vital importance that these installation sheets and their associated images are closely studied before undertaking the installation process.

LIVE/PHASE/FASE
RED
Rouge
Rojo



NEUTRAL/NEUTRE/NEUTRI
Black
Noir
Negro



EARTH/TERRE/TIERRA
Green/Yellow
Vert/Jaune
Verde/Amarillo



Earth if required

Power Supply
12V DC output

Electrical

Terminal block not included. Installation may require advice from a qualified person.

If a power supply is being used that was not supplied by Beadlight it is important to ensure that the power supply outputs 12 V DC.

It should be a regulated switch mode or linear stabilised power supply rated to at least 300ma. The power supply should be double insulated and should meet the appropriate national approvals (standards) in the country where the product is being installed.

From the lamp the Red wire is +12v DC and the Black wire 0v DC. These wires are to be connected to corresponding output wires from the 12v DC power supply.

This light is not intended for looping in.

If in doubt you must seek help from a competent electrical engineer.

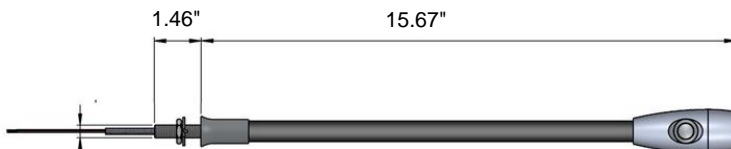

Light
Dimensions in inches

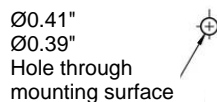

MOUNTING HOLE
Dimensions in inches



Jetstream Range/ Installation Instruction

Installation Process

First drill a 0.39" diameter hole at the point where the light is to be fitted (C),

The thread (A) is inserted into this hole from the front of the panel and the washer (B) and the nut (D) are then fitted onto the remaining protruding part of the thread.

Nut (D) can then be tightened to lock the lamp in place.

All that remains is to connect the light to a suitable power supply and switch it on using the switch located on the head.

Maintenance Information

The product should only be cleaned with a soft dry cloth no cleaning agents should be used.

There is no maintenance required for Beadlight products other than cleaning with a soft cloth, no cleaning agents are to be used. There are no parts that require servicing or maintenance. If there is a problem with a light these need to be returned to Beadlight to be assessed.

Warranty

Beadlight Limited will repair or replace a product free of charge if it fails to operate due to manufacturing defects within 5 years of purchase.

This guarantee does not include faults or damage caused by misuse, abuse, neglect, incorrect cleaning, accident or failure to follow assembly/installation instructions provided by Beadlight.

Product disassembly or servicing by non-Beadlight staff will void the warranty

Other Information

Avoid mounting the unit on damp or newly painted surfaces to avoid discolouration of finish.

If the external cable or cord of this luminaire is damaged, it shall be exclusively replaced by the manufacturer or his or her service agent or a similar qualified person in order to avoid hazard.

The product should only be cleaned with a soft dry cloth.

The light source of this luminaire is not replaceable; when the light source reaches its end of life the whole luminaire shall be replaced. At the end of the products life it can be returned to Beadlight to be disposed of under the WEEE regulations.

