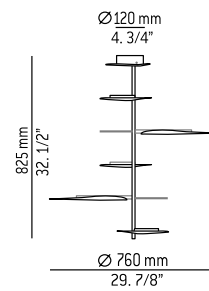
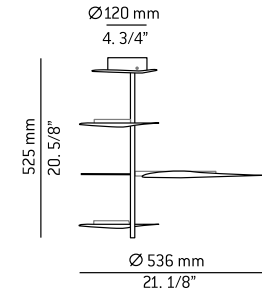

**T-3225 LED** 493032251

Colgante metálico con luz indirecta y pantallas orientables lateralmente 60°. Varillas adorno cromadas.

Metallic pendant providing indirect light. Adjustable heads with a lateral swing up to 60°. Decorative chrome sticks.

**IP**  
**20**

**960°**

**T-3225**

**T-3226**

LE RECOMENDAMOS LEA LAS INSTRUCCIONES ANTES DE PROCEDER A LA INSTALACIÓN. GUARDE LAS INSTRUCCIONES PARA FUTURAS REFERENCIAS.

- \* Asegúrese de que la corriente está desconectada antes de conectar el aparato.
- \* El montaje de luminarias debe ser efectuado solamente por personal técnico.
- \* No utilizar bombillas con potencia superior a la indicada en la etiqueta.
- \* Únicamente para uso en interiores.
- \* Para limpieza no utilizar alcohol ni disolventes
- \* Recomendamos la intervención de 2 personas para el montaje de la lámpara

WE RECOMMEND TO READ THE INSTRUCTIONS ENTIRELY BEFORE STARTING YOUR INSTALLATION. PLEASE SAVE THESE INSTRUCTIONS SO THAT YOU CAN REFER TO THEM A LATER TIME.

- \* Make sure the power has been disconnected before installing the fixture.
- \* Lighting fixtures should be installed only by qualified personnel.
- \* Make sure the bulb never exceeds the maximum wattage specified on the fixture label.
- \* For indoor use only.
- \* Do not use alcohol or disolvents to clean the lamp
- \* For your convenience assembly by two people ist recommended.

**Instrucciones / Assembly instructions**
**Atención: / Warning:**

No mirar directamente a los LED.  
 Do not look directly into any LED source  
 Bitte nicht direkt in die LED schauen  
 Ne regardez jamais les ampoules LED directement

1- Desenroscar los tornillo laterales del tapapared (A). Liberar la sujeción (B). Figura 1.

1- *Unscrew the lateral screws (A) to remove the canopy (A) from the mounting bracket (B). Figure 1.*

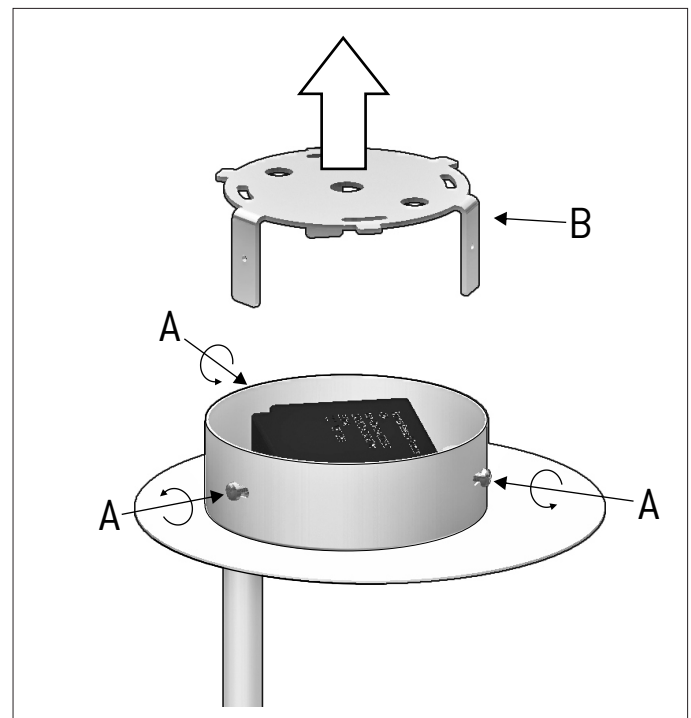
**1**

2- Introducir los cables de la red eléctrica hacia el interior de la sujeción (B). Atornillar la sujeción (B) al techo. Figura 2.

2- *Insert the electrical wires from the outlet box into the mounting bracket (B). Affix the mounting bracket (B) to the ceiling or the electrical junction box. Figure 2.*

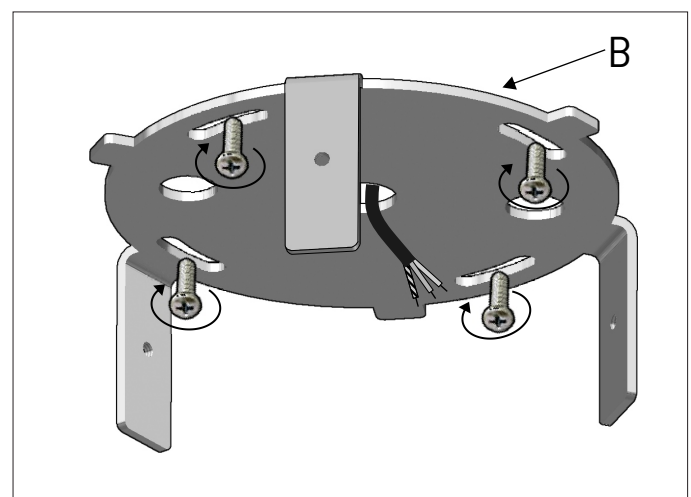
**2**

### Assembly instructions

3- Realizar las conexiones eléctricas. Acoplar la lámpara a la sujeción (B) y atornillar de nuevo los tornillos liberados anteriormente en el paso 1. Figura 3.

3- Connect the wires. Attach and affix the lamp to the mounting bracket (B). Tighten the screws removed previously in step one. Figure 3.

**Atención: la manecillas (C) sólo sirven de adorno. No utilizarlas para girar la lámpara.**

**Attention! Decorative sticks (C) only. It can not be used to rotate the shade.**

# 3

