

NEMO GROUP 2025

1993



Cassina

2012

NEMO

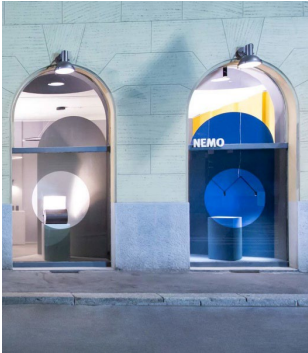

Showroom - Milano

2014

NEMO

2017

NEMO FRANCE



Showroom - Parigi

2020

NEMO USA



Nemo Lighting USA

2020

NEMO

acquired majority stakes in ILTILUCE

ILTILUCE

2023

NEMO

acquired majority stakes in REGGIANI and 2% stakes in ZUMTOBEL Group

Reggiani

zumtobel group

2024

NEMO

acquired majority stakes in FONTANA ARTE and DRIADE

FontanaArte
driade

Global presence

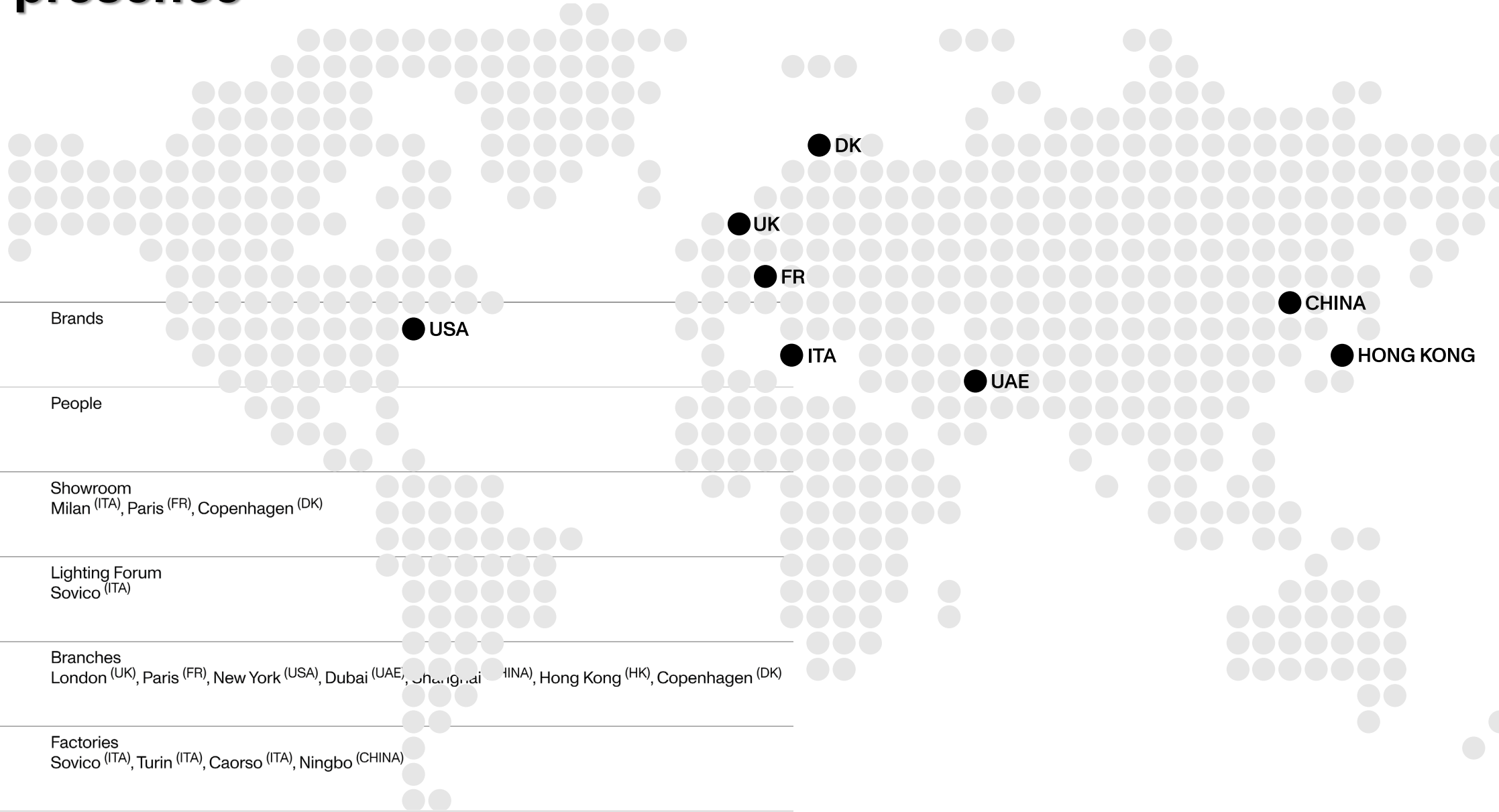

5

Brands

● USA

250

People

3

Showroom

Milan (ITA), Paris (FR), Copenhagen (DK)

1

Lighting Forum

Sovico (ITA)

6

Branches

London (UK), Paris (FR), New York (USA), Dubai (UAE), Shanghai (CHINA), Hong Kong (HK), Copenhagen (DK)

4

Factories

Sovico (ITA), Turin (ITA), Caorso (ITA), Ningbo (CHINA)

Headquarter



NEMO^{USA}

NEMOLIGHTING.COM/USA

Reggiani **IL TILUCE** FontanaArte **driade**
NORTH AMERICA



1Cape May St
New Jersey 07029

QS Quick Shipping program available

“TOGETHER STRONGER THAN EVER”

CONTEMPORARY COLLECTION

Products designed by the contemporary designers like:

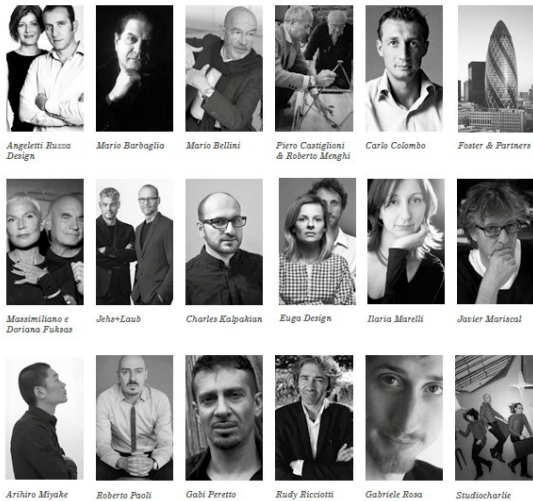

MASTERS COLLECTION

Products designed by the Masters of the XX century architecture like:

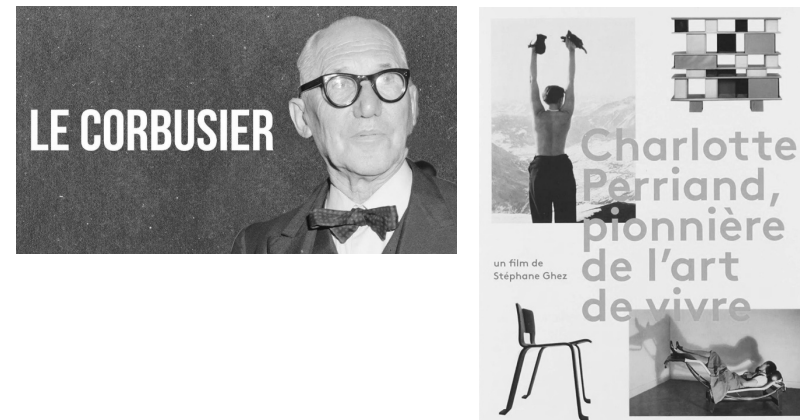

CUSTOM SOLUTIONS:

OPTION A:
modify shapes and sizes of
products already in the catalog



modification of the standard
ZIRKOL

OPTION B:
make a new product that is
not present in the catalog

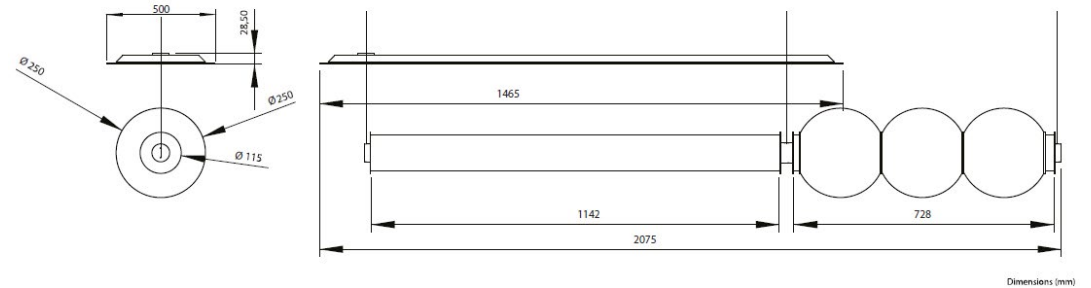

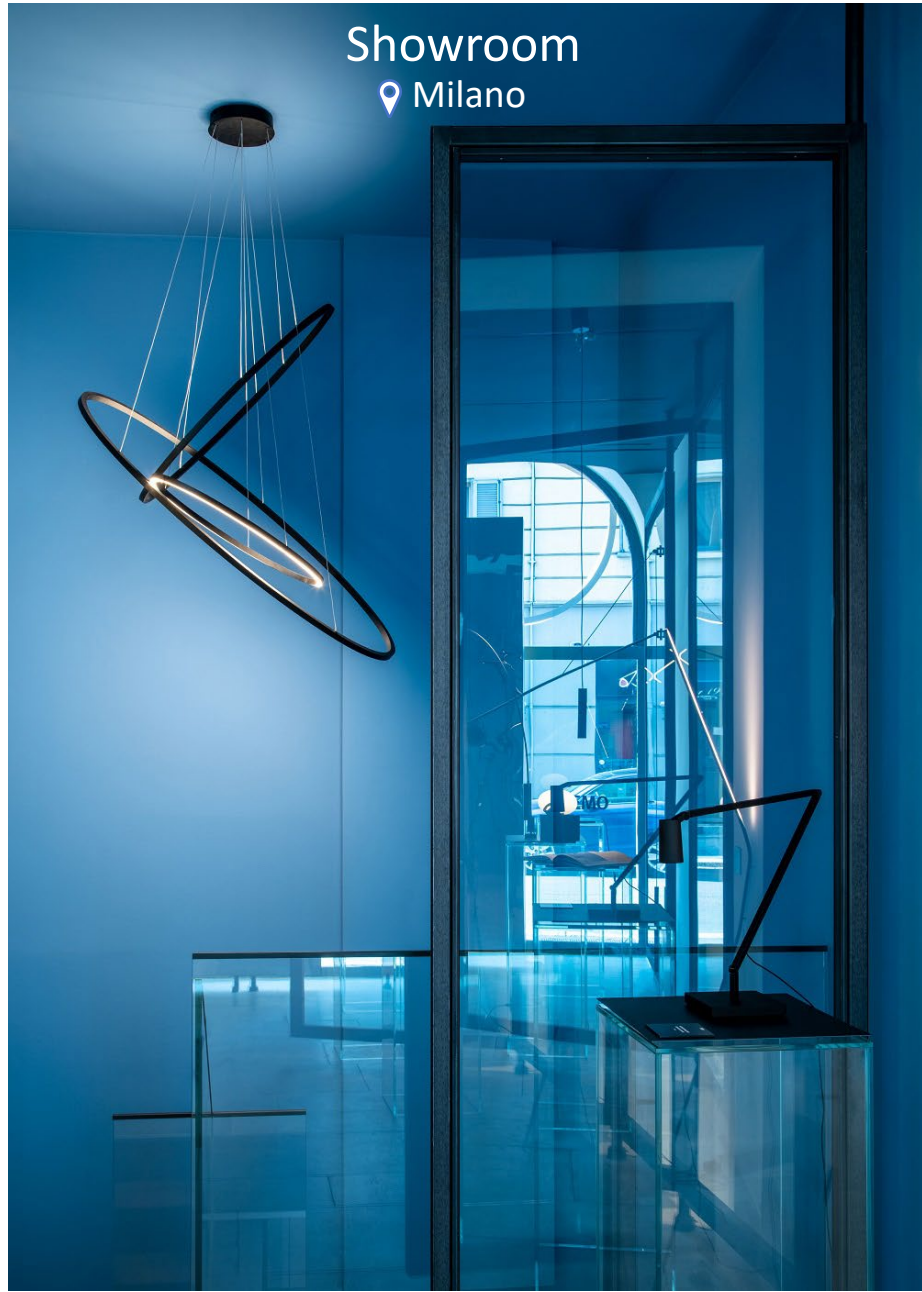

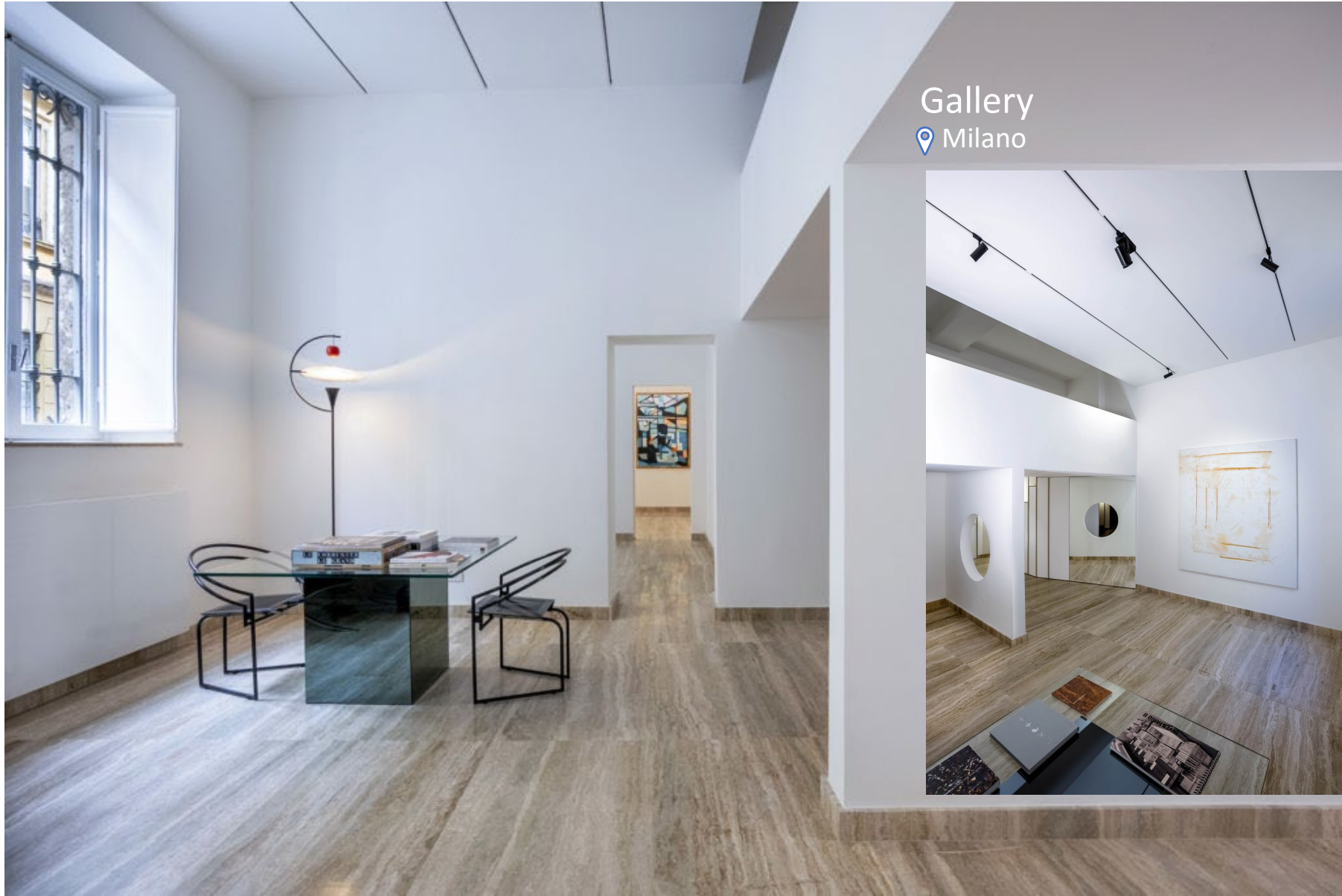

Gallery

Milano





Showroom

📍 Paris

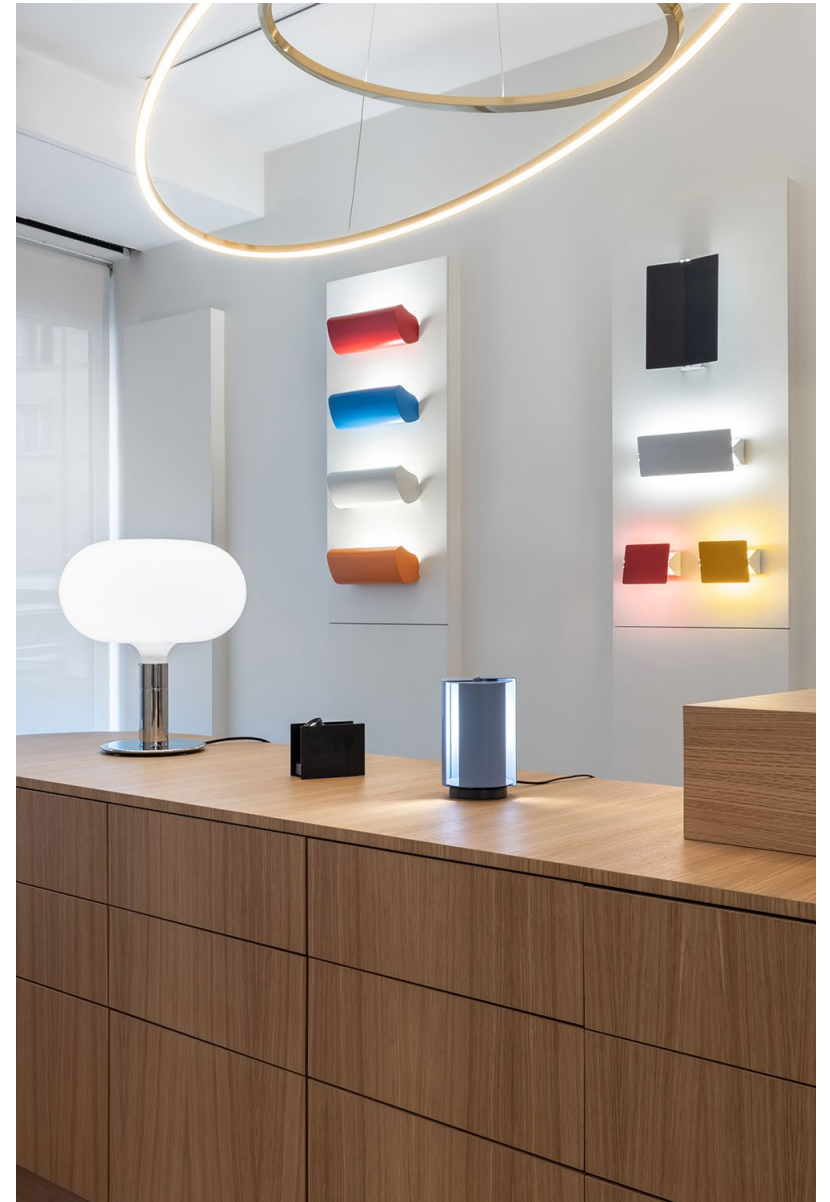

Showroom

📍 Copenhagen

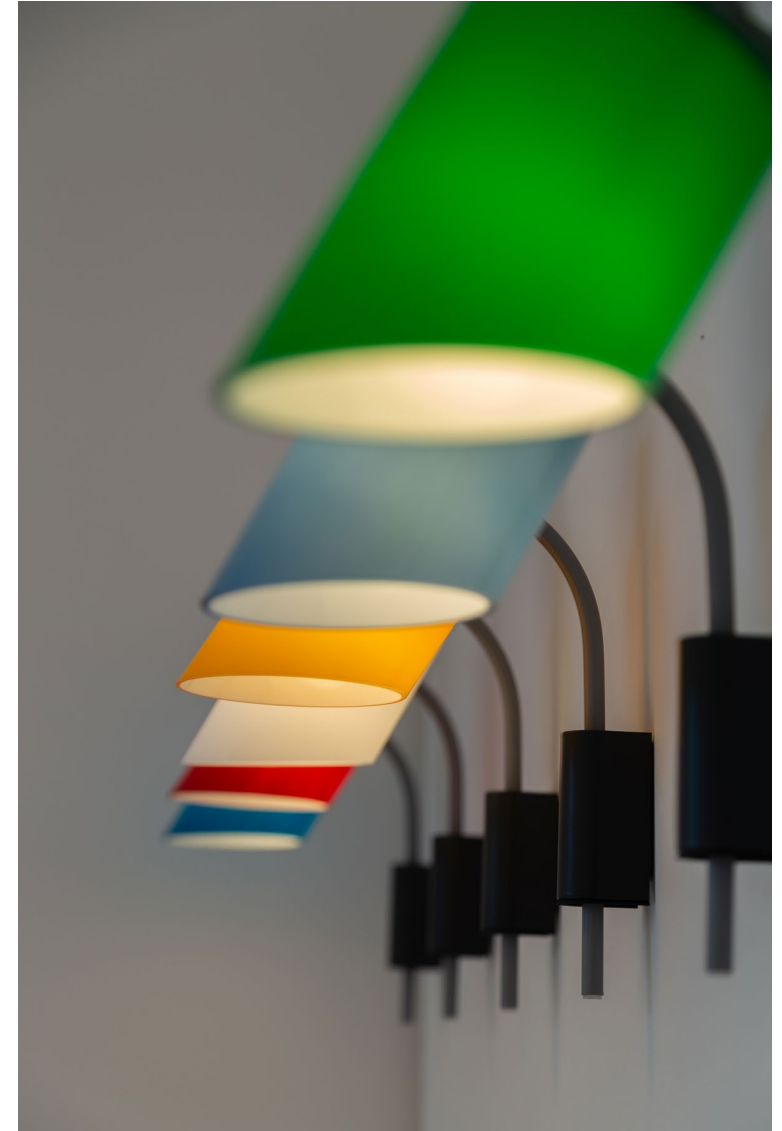

CONTEMPORARY COLLECTION

PENDANT LAMPS



Álvaro Siza

LOROSAE

ALVARO SIZA, 1999



Basilica Palladiana, Vicenza. Italy

LOROSAE

- Three dimming levels
- Three dimensions

LOROSAE Ø20



LOROSAE Ø30

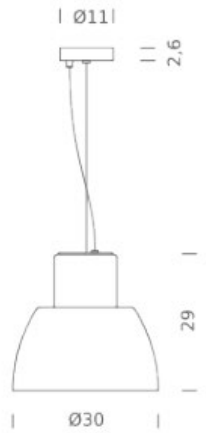

LOROSAE Ø40

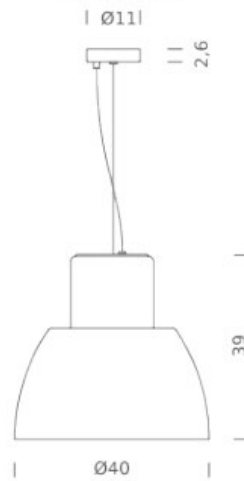





LOROSAE Table

- Integrated Led
- Outdoor (wet rated) and Indoor





DROP

Arihiro Miyake



● black

● satin gold

● satin silver

- Three dimensions
- Drop 5/7/9

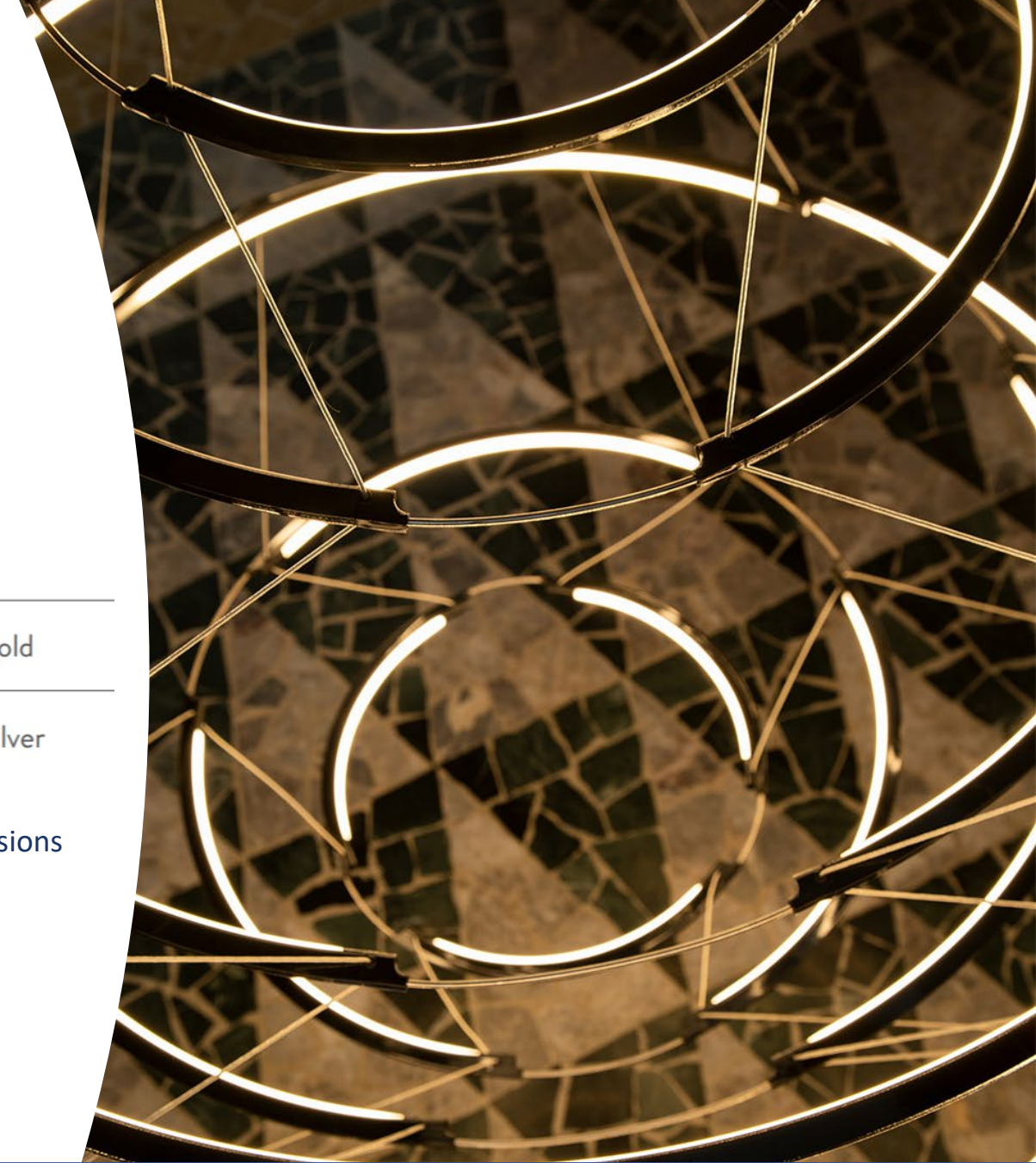







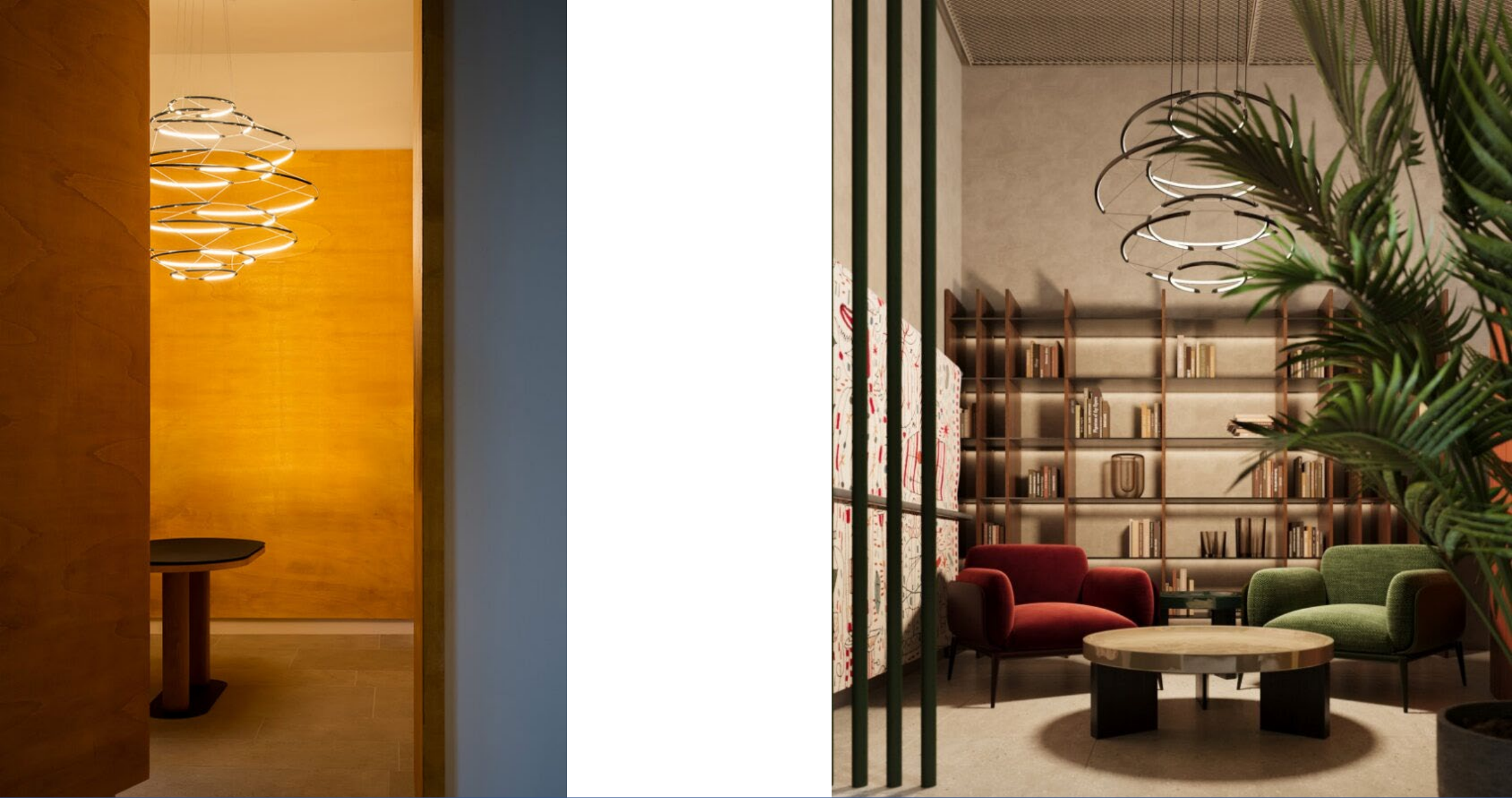



ELLISSE

Federico Palazzari

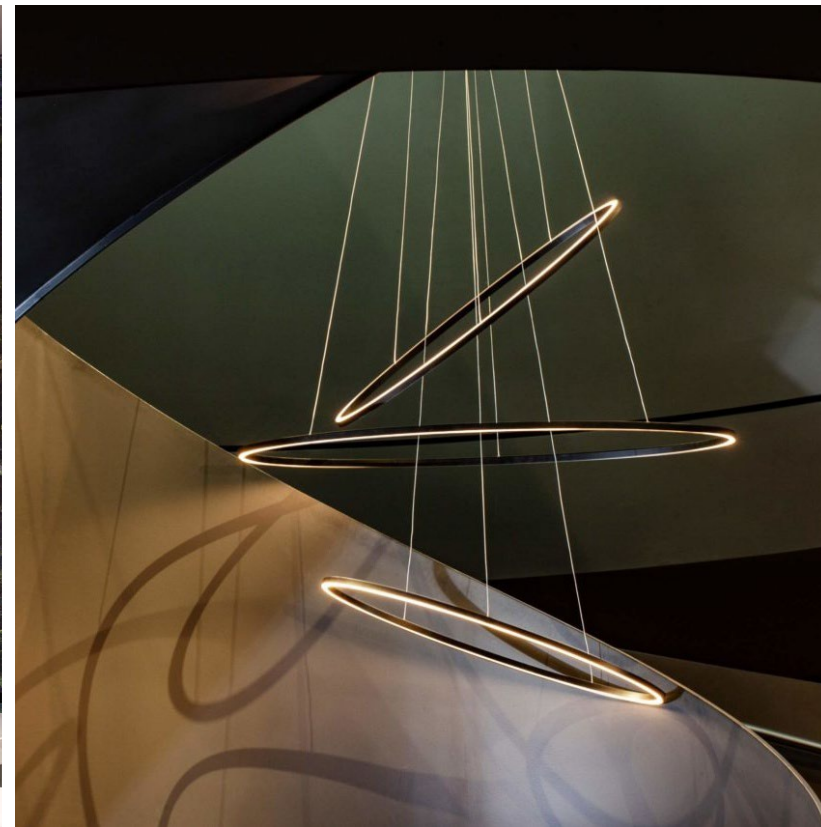





MINOR

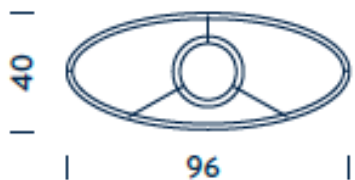

DOUBLE

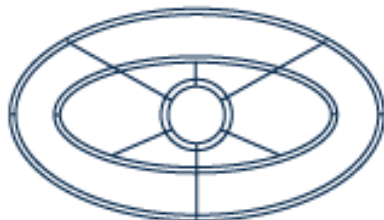

MAJOR

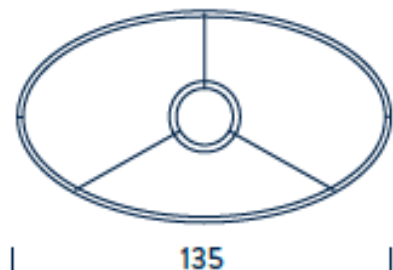

DOUBLE MEGA

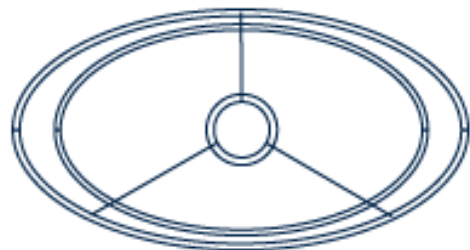

MEGA

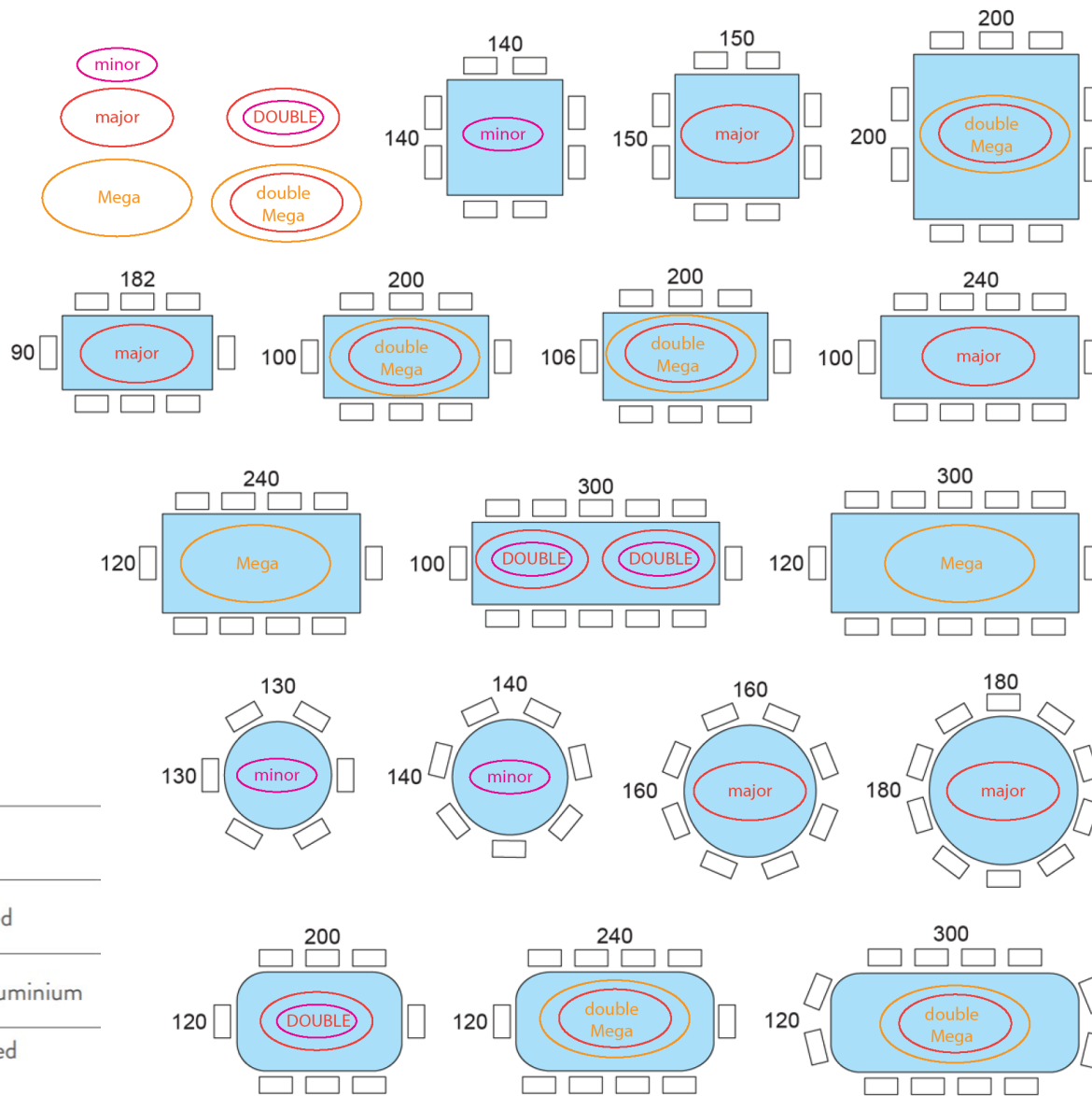
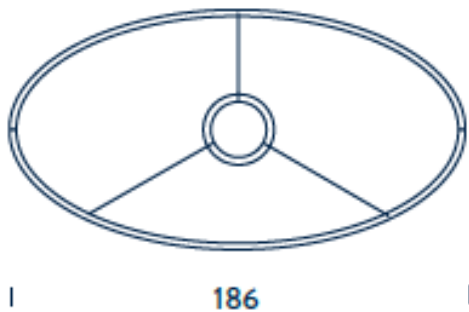

- white
- black
- gold painted
- polished aluminium
- gold polished anodized

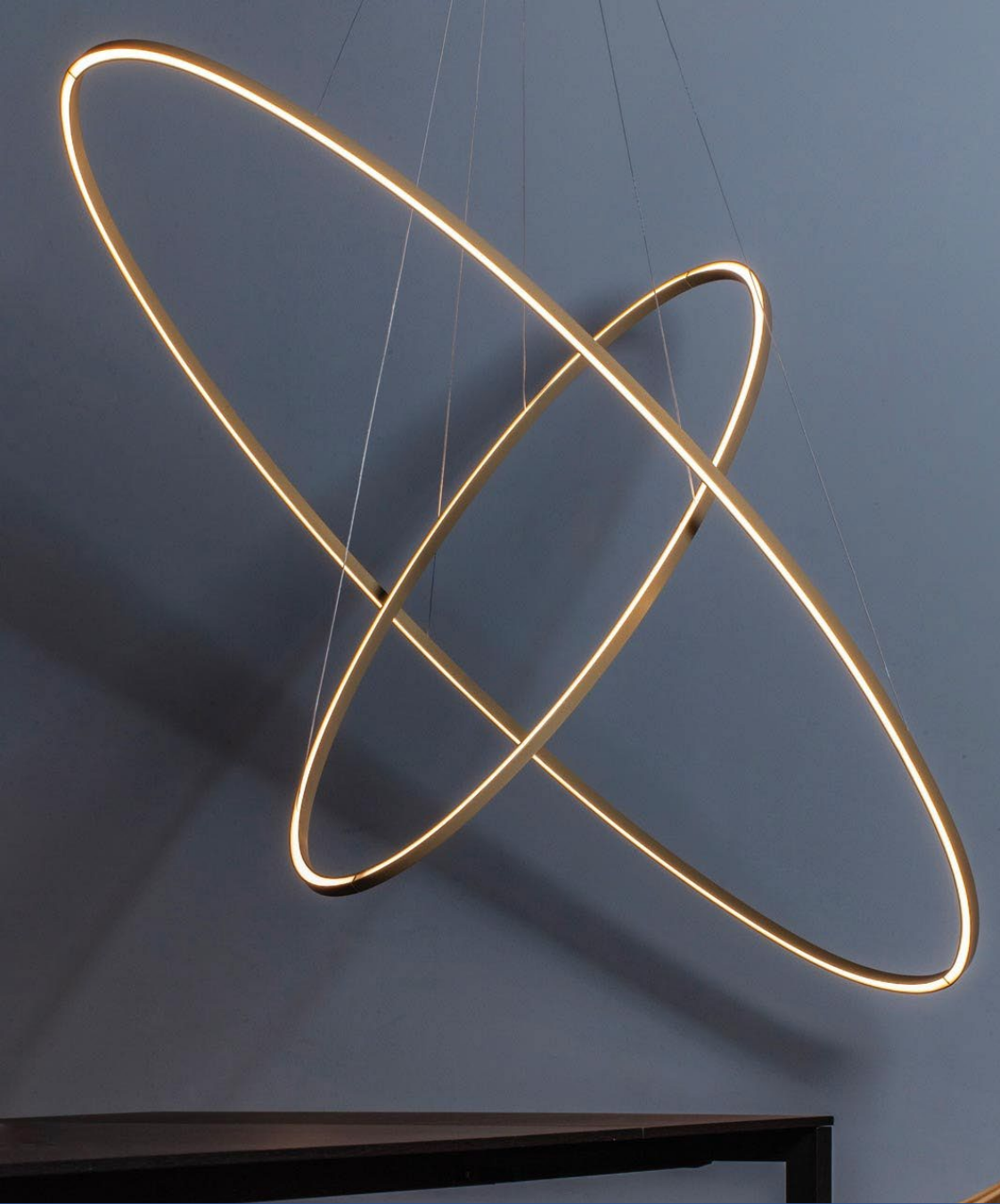





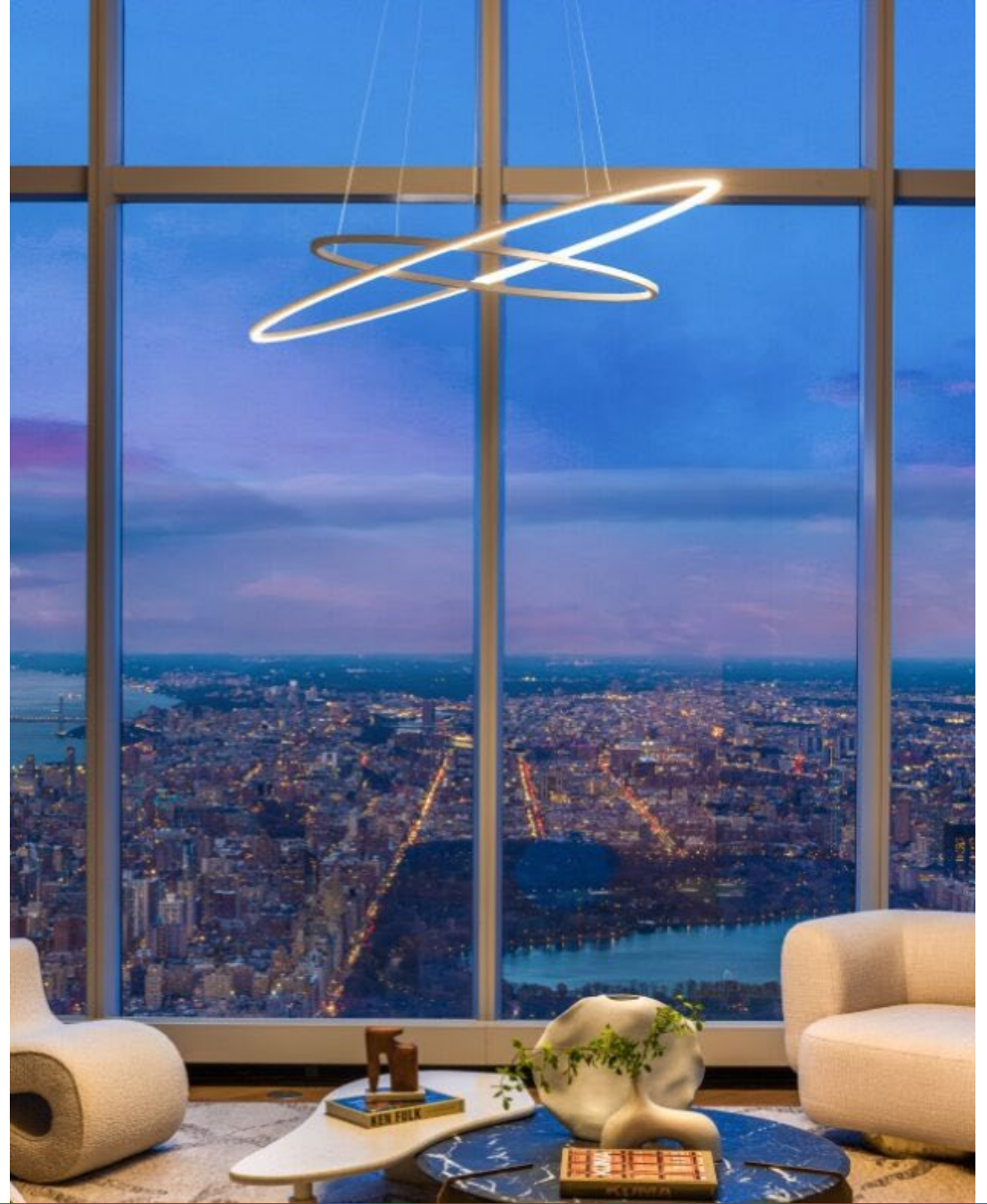
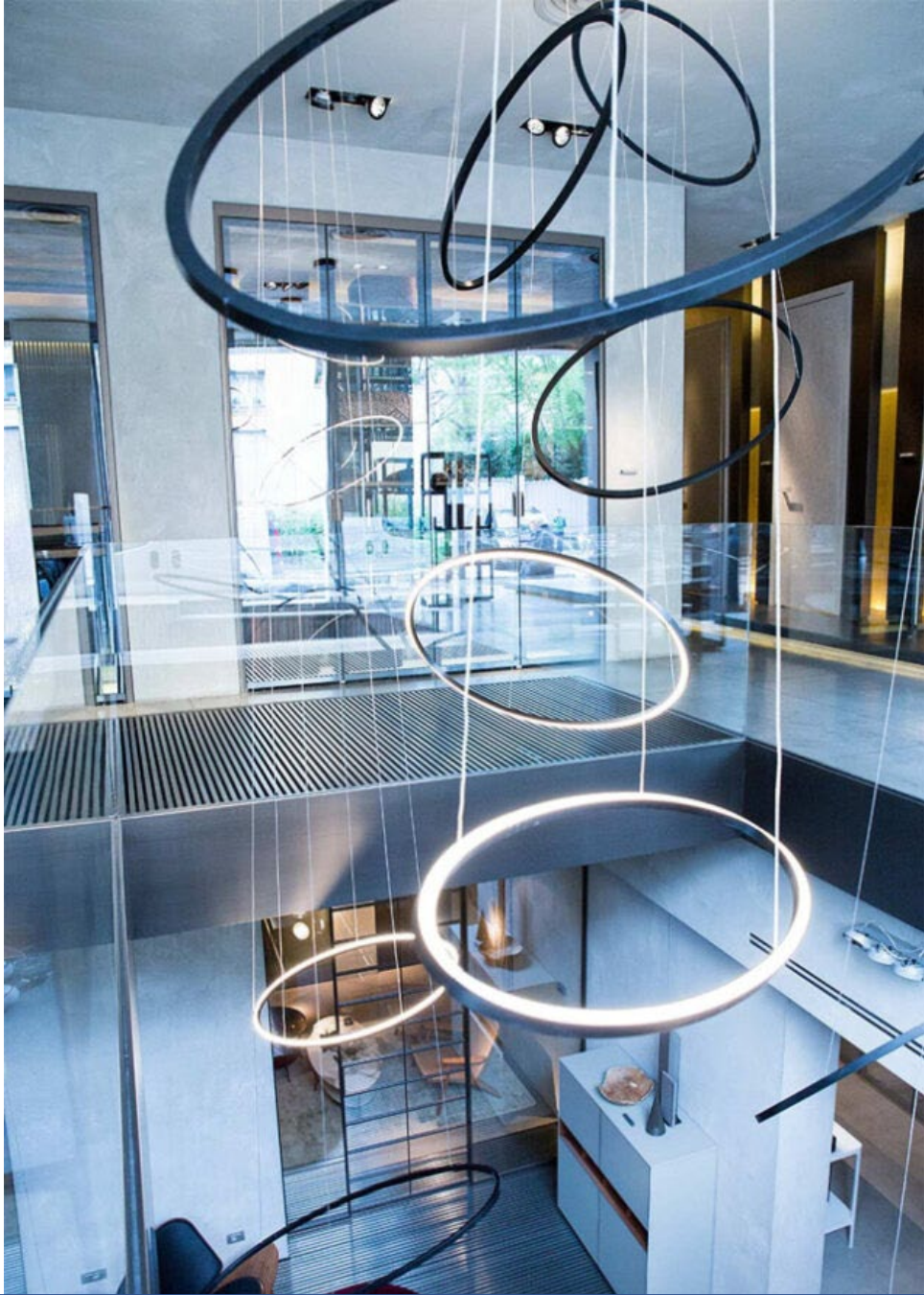









ELLISSE TRIPLE

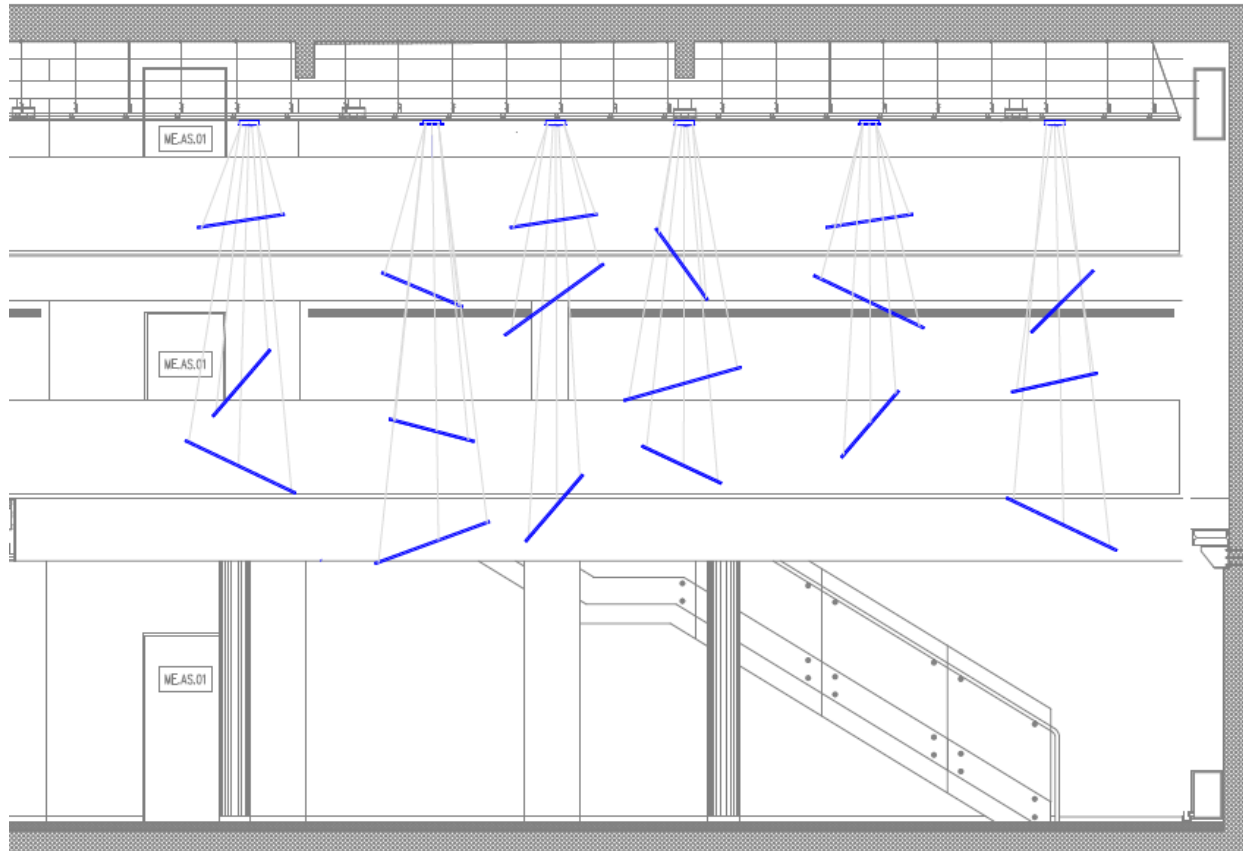



IN THE WIND

Arihiro Miyake

white

black

titan grey

gold











WORKagency

Agenzia per il Lavoro



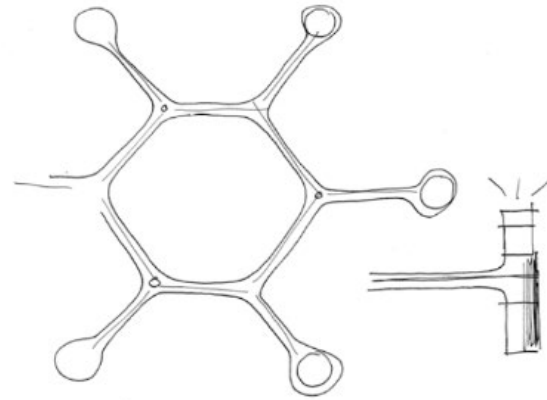

Jehs Laub

CROWN

Jehs+Laub

- 4 dimensions
- Minor, major, summa, magnum, royal
- Plana
- Double

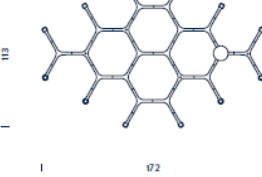
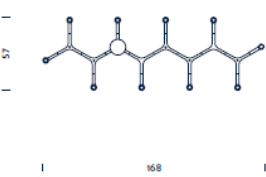
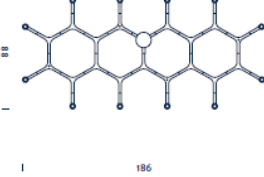
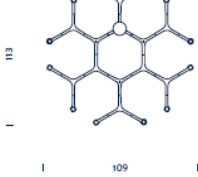
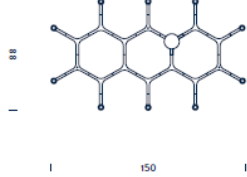
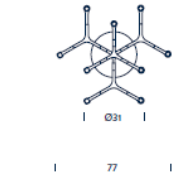
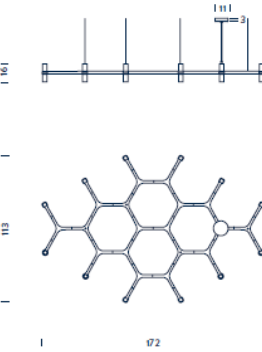
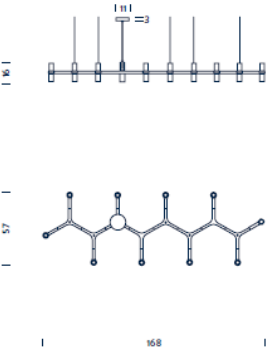
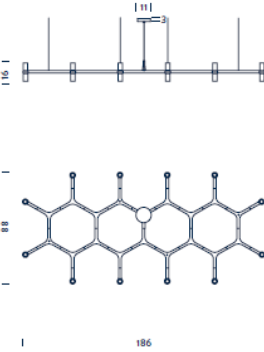
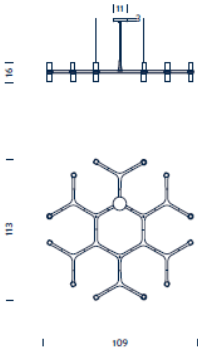
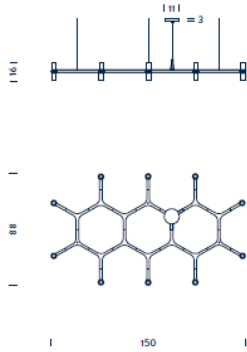
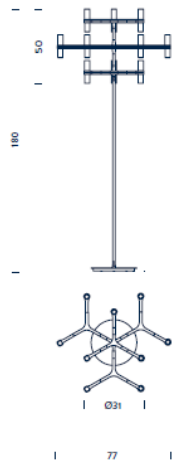
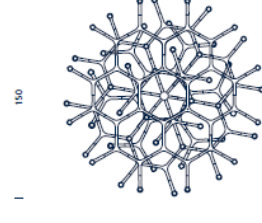
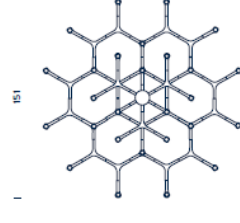
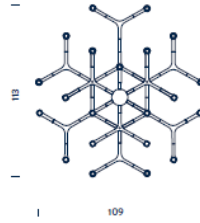
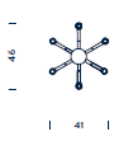
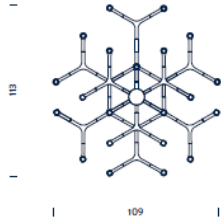
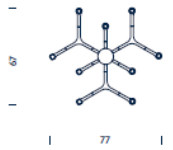
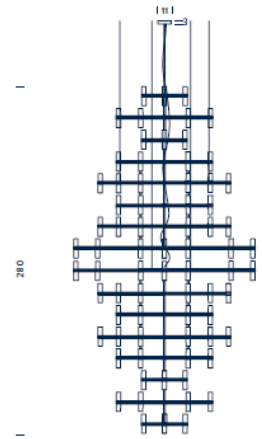
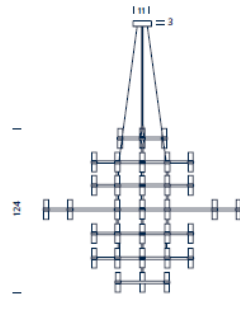
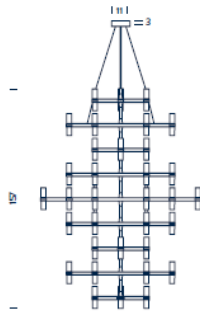
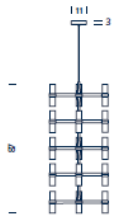
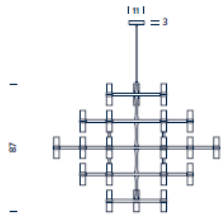
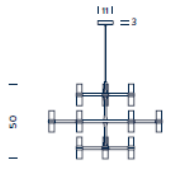



○ white

● black

● gold painted

● polished aluminium

● gold plated

● black plated

G9 bulbs

CROWN

Jehs+Laub



Minor



Major



CROWN

Jehs+Laub



CROWN SUMMA

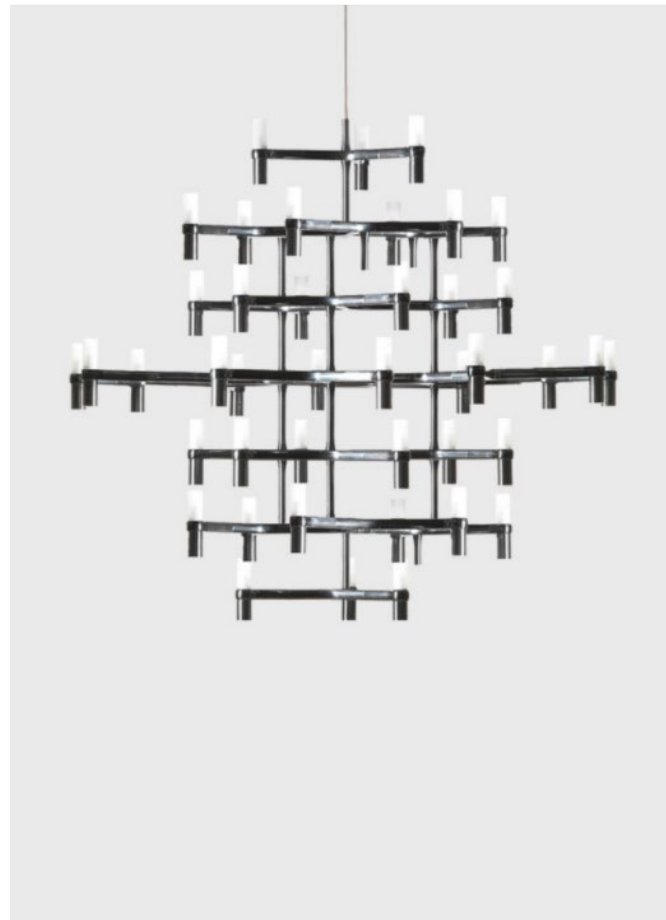

CROWN MAGNUM



CROWN ROYAL























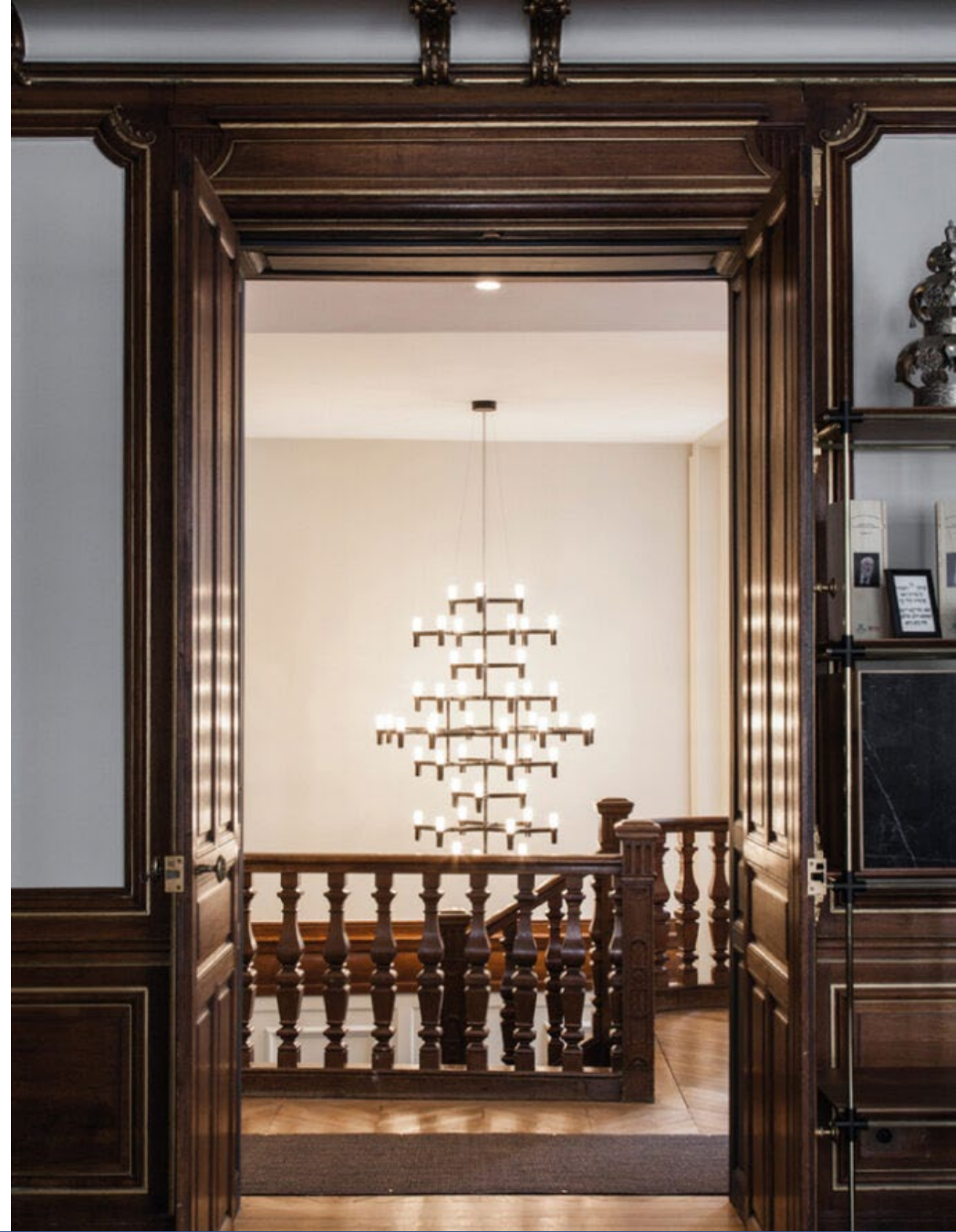







CROWN

Jehs+Laub



CROWN

Jehs+Laub

















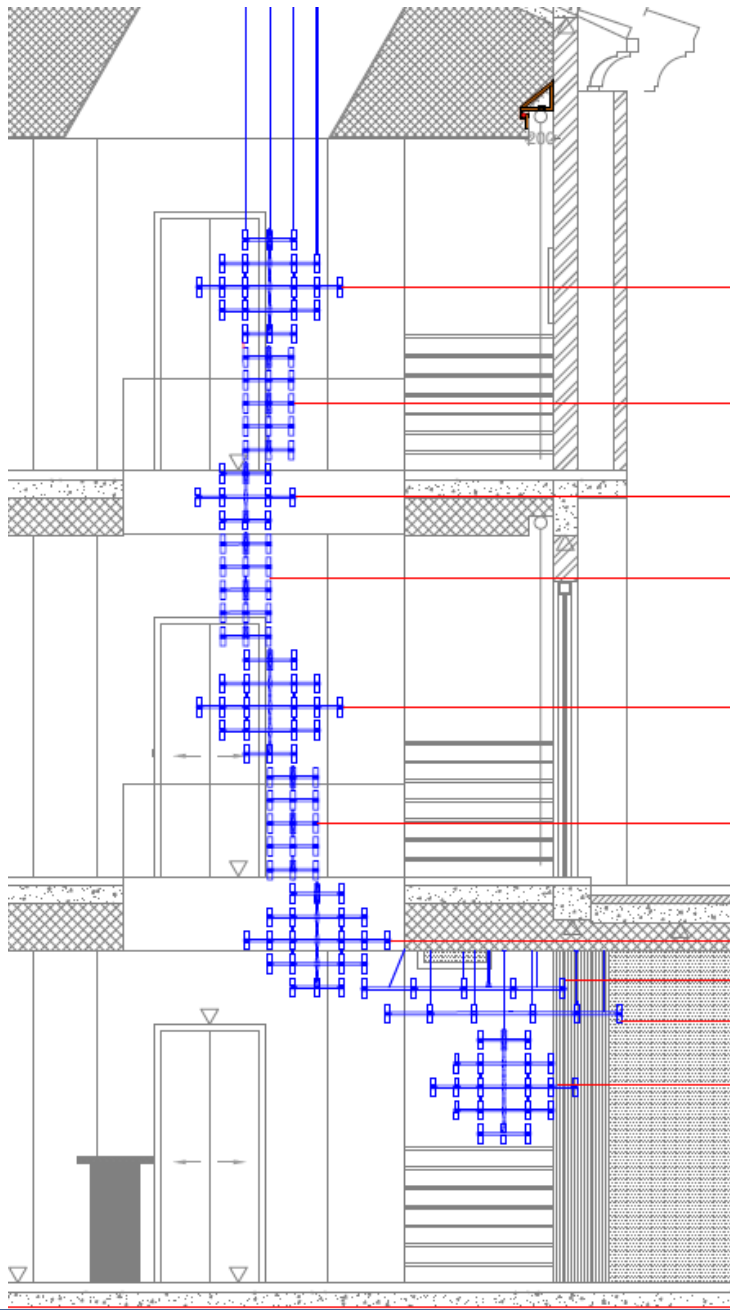

REF. CROWN M₁
Crown Major Led

REF. CROWN M₂
Crown Multi Led

REF. CROWN M₃
Crown Minor Led

REF. CROWN M₄
Crown Multi Led

REF. CROWN M₅
Crown Major Led

REF. CROWN M₆
Crown Multi Led

REF. CROWN M₇
Crown Major Led

REF. CROWN P₁
Crown Plane Led

REF. CROWN P₂
Crown Plane Major Led

REF. CROWN M₈
Crown Major Led



REF. CROWN M₁
Crown Major Led



REF. CROWN M₂
Crown Multi Led



REF. CROWN M₄
Crown Multi Led



REF. CROWN P₂
Crown Plane Major Led



REF. CROWN P₁
Crown Plane Led

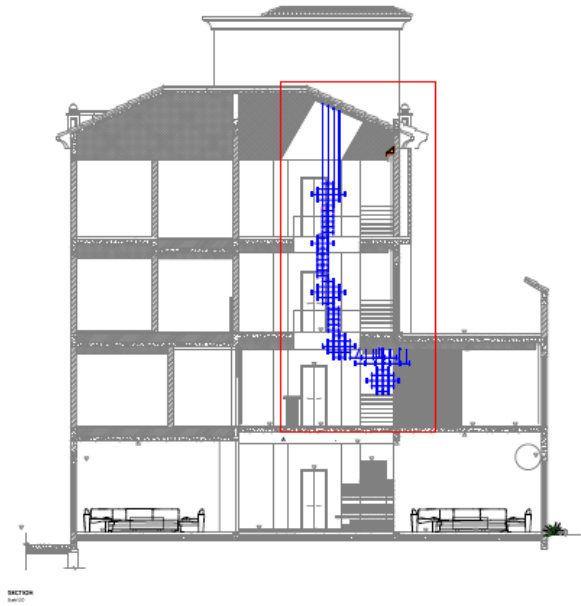

SECTION
01/20/20

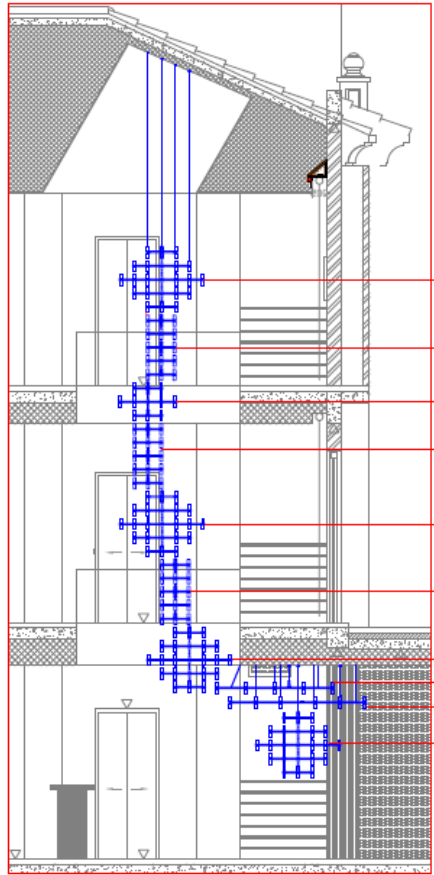

REF. CROWN M₁
Crown Major Led

REF. CROWN M₂
Crown Multi Led

REF. CROWN M₃
Crown Minor Led

REF. CROWN M₄
Crown Multi Led

REF. CROWN M₅
Crown Major Led

REF. CROWN M₆
Crown Multi Led

REF. CROWN M₇
Crown Major Led

REF. CROWN P₁
Crown Plane Led

REF. CROWN P₂
Crown Plane Major Led

REF. CROWN M₈
Crown Major Led

DETAIL
01/20/20

LEGENDA

ref.	description	quantity	W	h	W
REF. CROWN M ₁	CROWN MAJOR LED	1	100	100	100
REF. CROWN M ₂	CROWN MULTI LED	1	100	100	100
REF. CROWN M ₃	CROWN MINOR LED	1	100	100	100
REF. CROWN M ₄	CROWN MULTI LED	1	100	100	100
REF. CROWN M ₅	CROWN MAJOR LED	1	100	100	100
REF. CROWN M ₆	CROWN MULTI LED	1	100	100	100
REF. CROWN M ₇	CROWN MAJOR LED	1	100	100	100
REF. CROWN P ₁	CROWN PLANE LED	1	100	100	100
REF. CROWN P ₂	CROWN PLANE MAJOR LED	1	100	100	100
REF. CROWN M ₈	CROWN MAJOR LED	1	100	100	100
TOTAL QUANTITY		10			





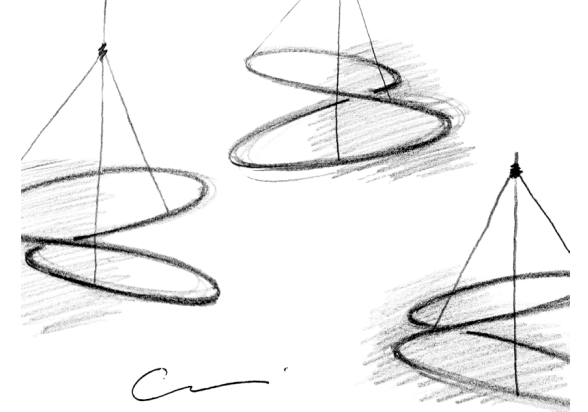

- Three dimensions
- Minor, standard, petite

○ white

● black

● gold

KEPLER

Arihiro Miyake

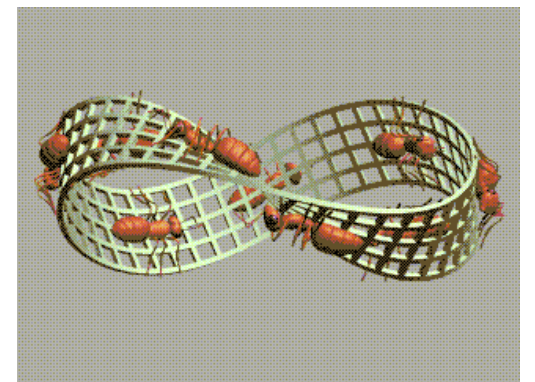











NUVOLA

Mario Bellini 1974



154

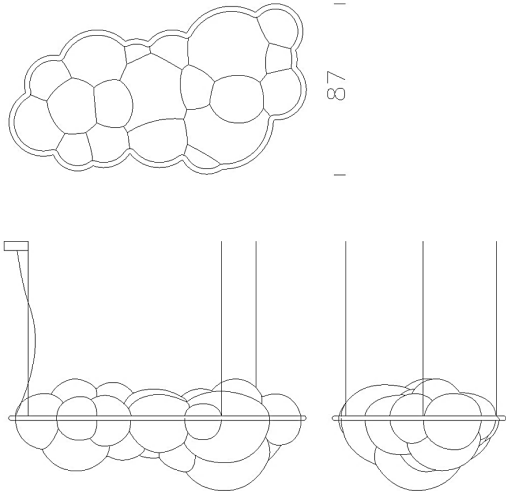

2D model

LED

LAMPING

Source	Linear LED
Total power	132W
Emission	diffused
Switching	dimmable, 1-10V
Tension	110/240V
Color temperature	2700K
Luminous flux	12000lm (source luminous flux)
Typ cri	85
Energy class	A+
Materials	polyethylene
Notes	cable length 3m, also available in 120V, DALI version on request

Net lamp weight

11 kg

Codes
NUV LWW 51

Structure
white

PACKAGE
Package 01

Dimension: 94x167x69 cm / Gross weight: 19 kg

Certificazioni
CE ENEC

Datasheet / technical characteristics

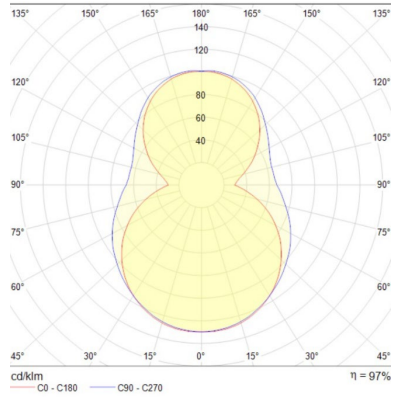

Photometric curve
(.ldt and .ies)

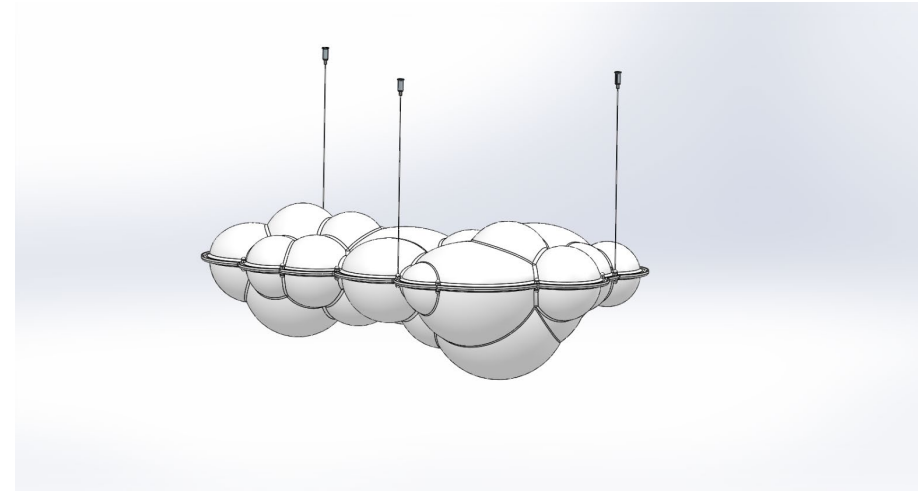

3D model

- Two dimensions: standard or petite
- Wall or pendant















NUVOLA MINOR

Mario Bellini







TRU Pendant

Roberto Paoli



white

black

titan grey

TRU Pendant

Roberto Paoli



ZIRKOL

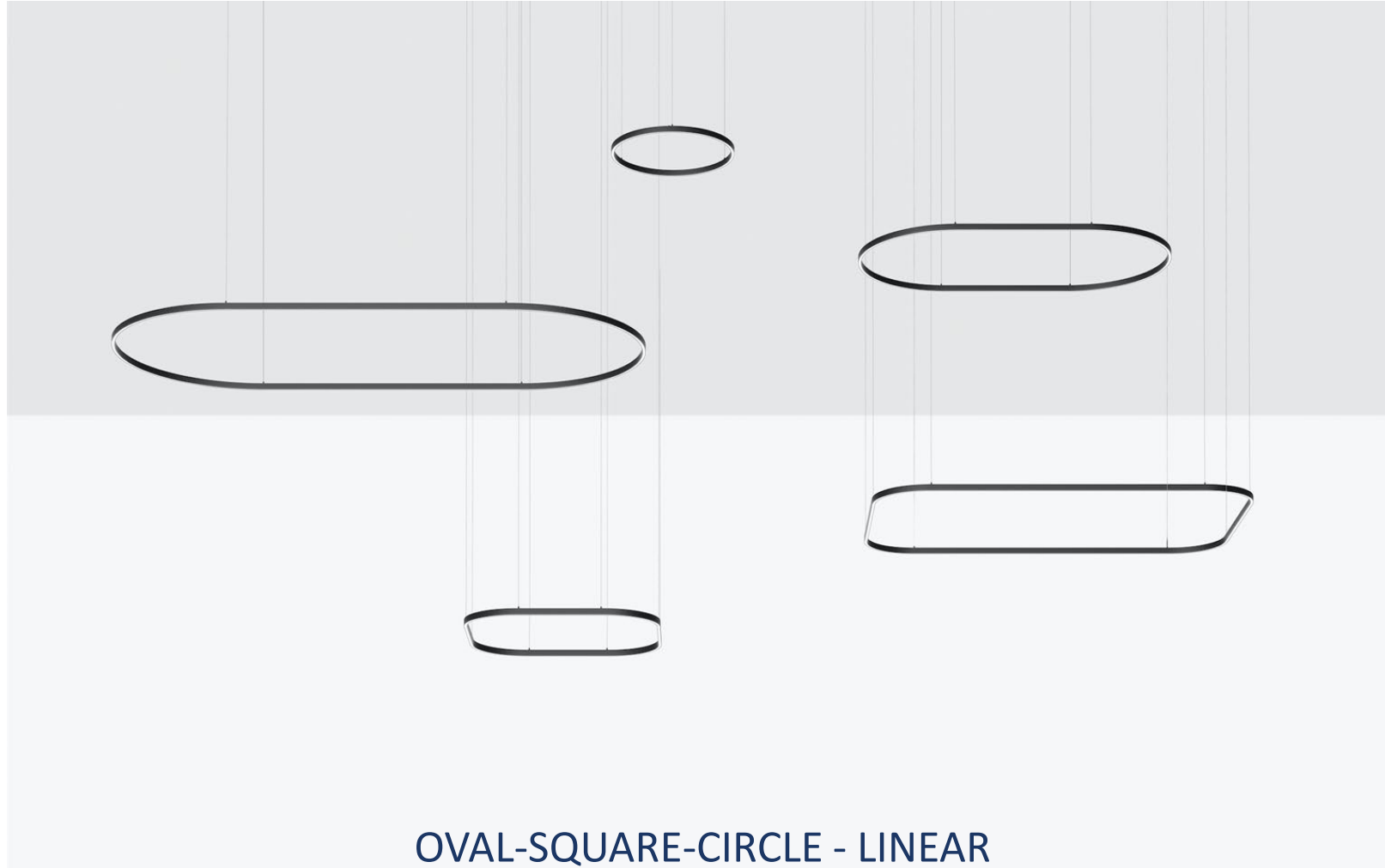

OVAL-SQUARE-CIRCLE - LINEAR

ZIRKOL

- Aluminium 6060 T5 extruded profile
- Homogeneous light distribution: **opal screen**
- Mechanical and electrical **couplings** for quick and easy fixing
- Direct or indirect **light emission**
- **CRI 90**
- **Dimmable 0-10V**
- Three **finishes** available: *matt white, matt black and matt gold*

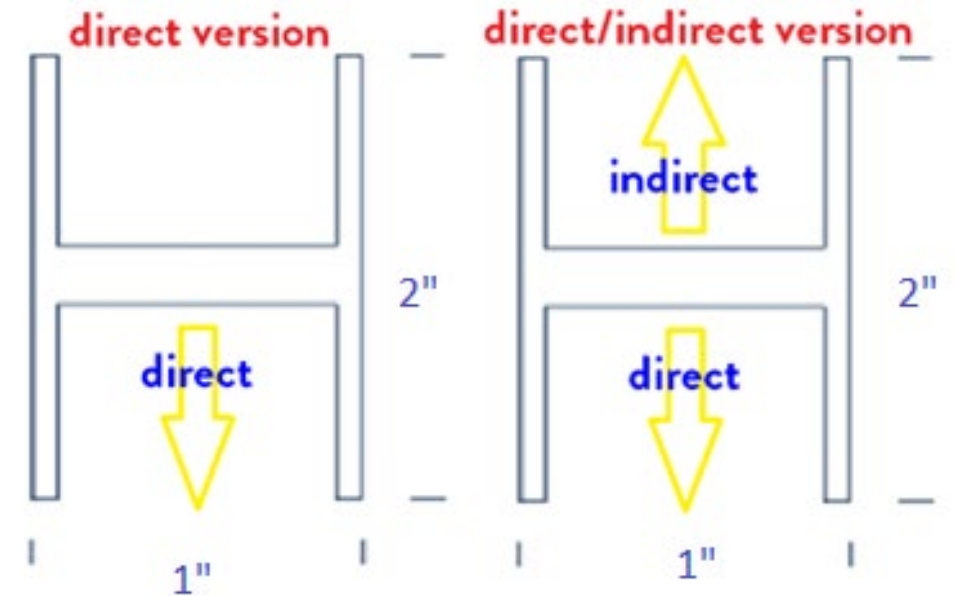

○ white

● black

● gold

THE ZIRKOL COLLECTION

Its uniqueness lays in the essentiality of the shape

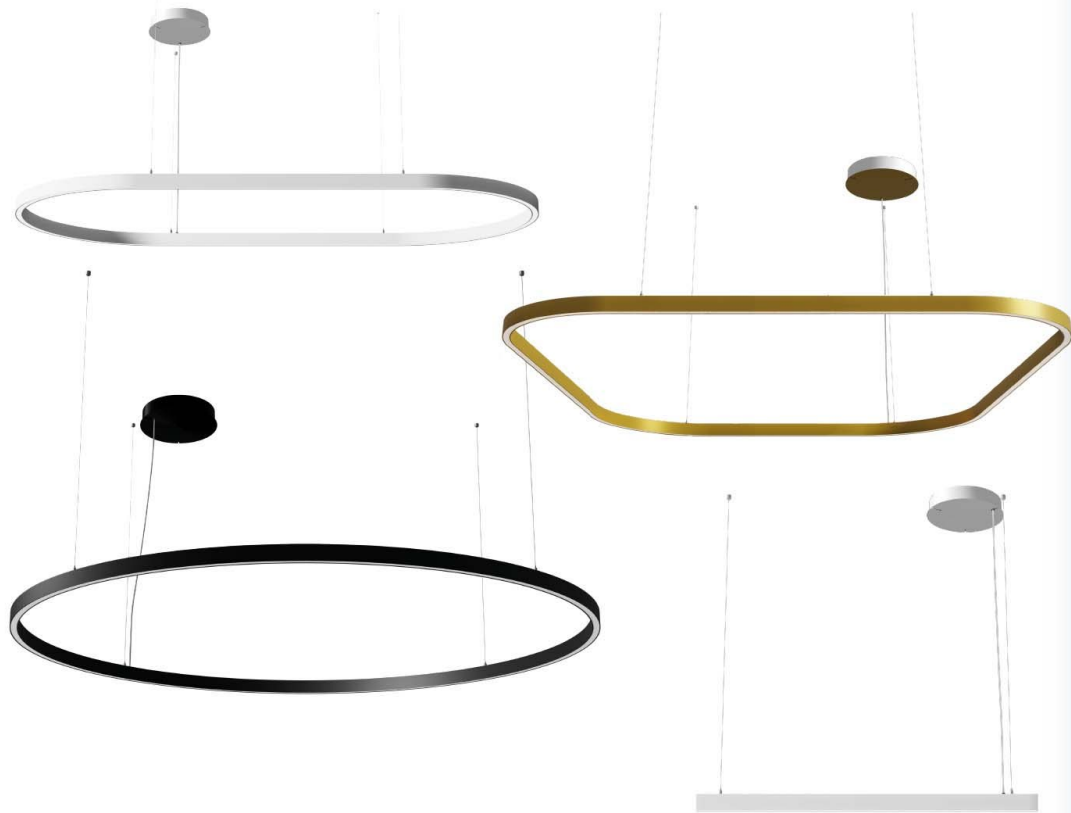

*Specific RAL/FINISHING on request



NEMO STUDIO

ZIRKOL | CIRCLE

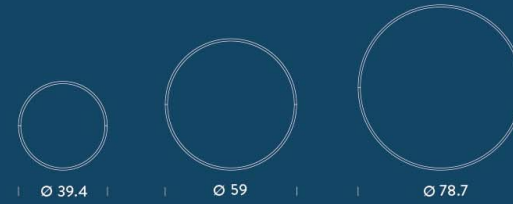

ZIRKOL | SQUARE

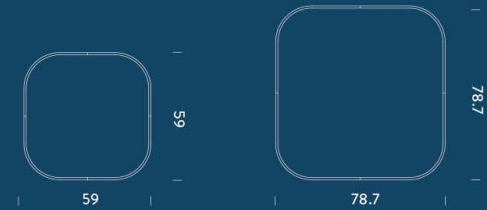

ZIRKOL | LINEAR



ZIRKOL | OVAL



ZIRKOL | CUSTOM

LINEAR

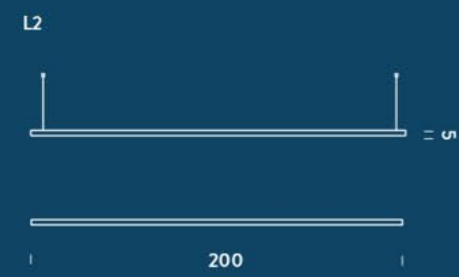
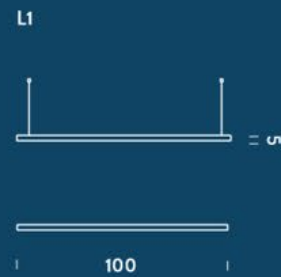

ROUND



ANGLE

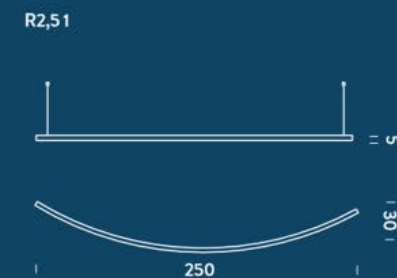
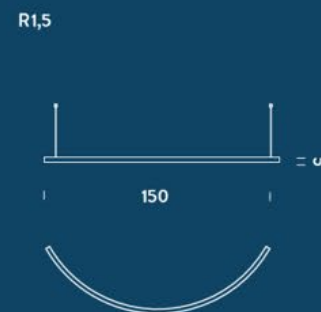



















Custom solutions







Custom solutions





ZIRKOL ABACO + CUSTOM

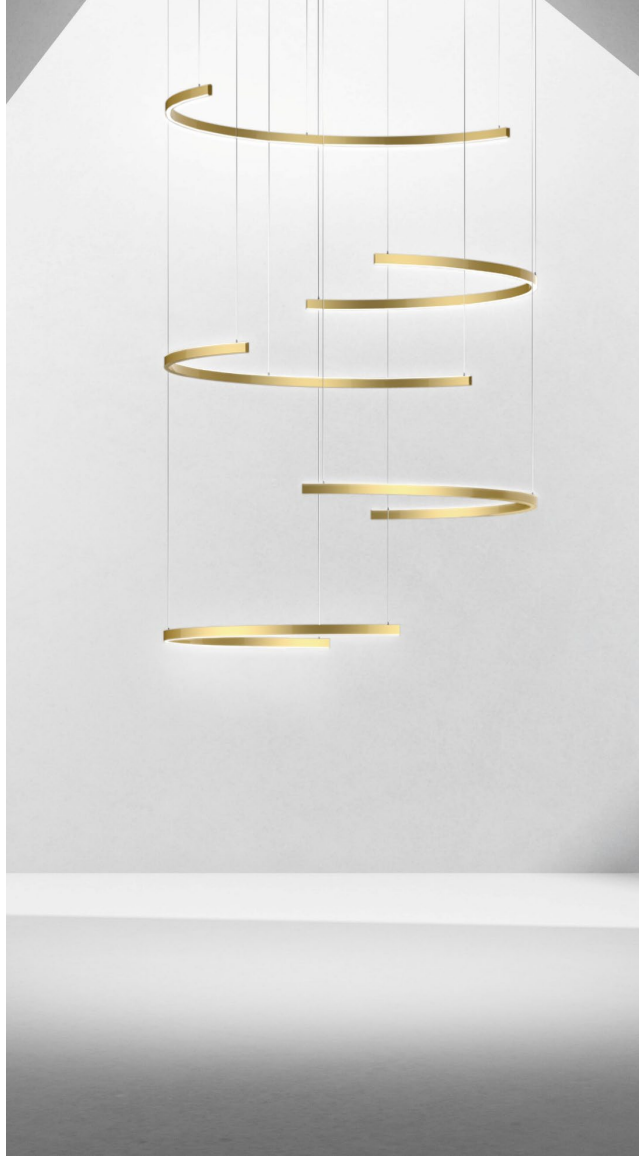

LINEAR

L1

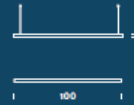

L2

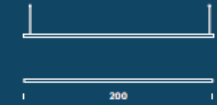

ROUND

D1



D1,5



D2



ANGLE

R1,5



R2,5

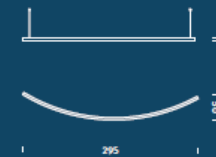

R0,4





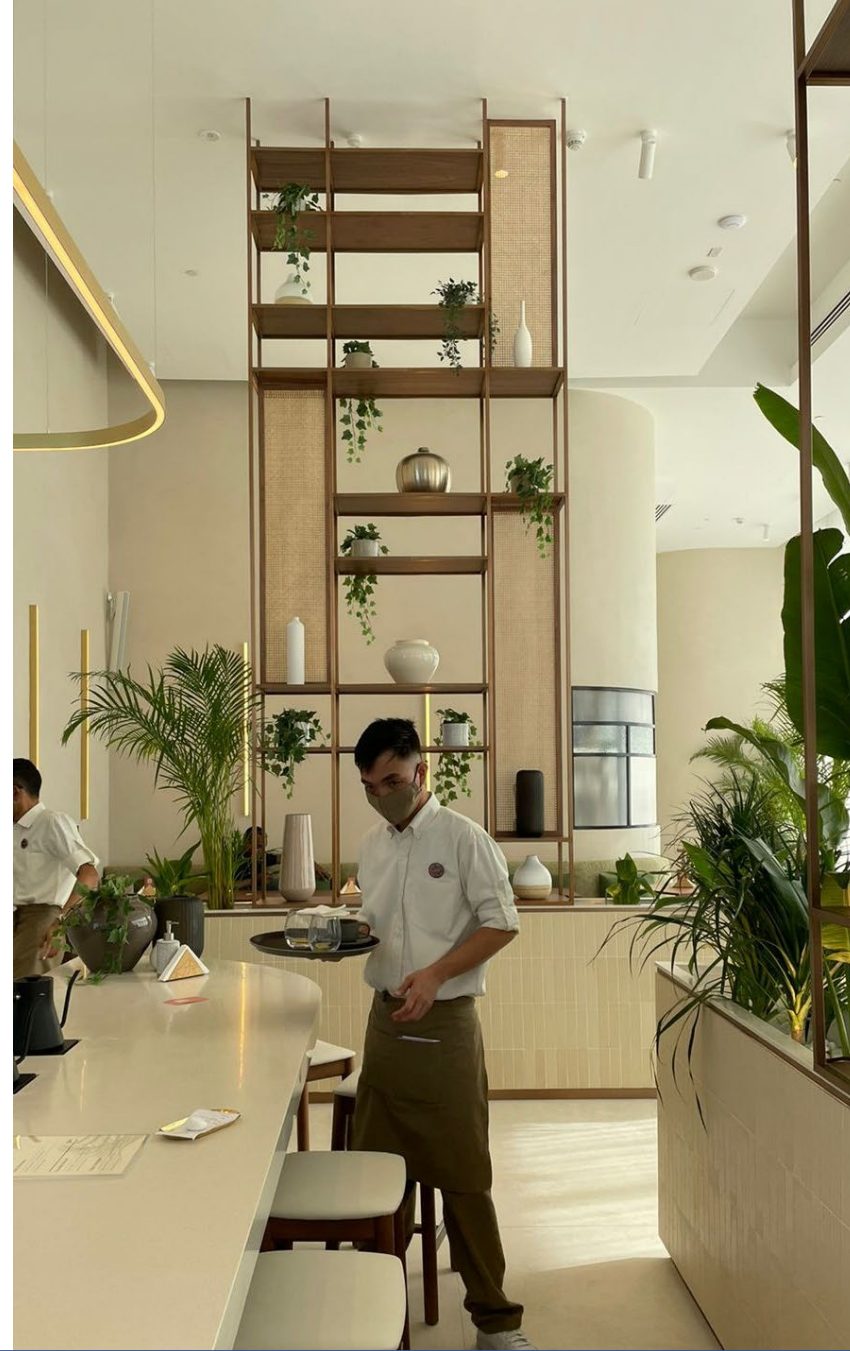









Menu Board
- Absolu de Charente Le Domaine - 77€
- Absolu de France - 4€
- Robette de Cote Pomerain - 21€
- Robette de Jumeau Pomerain - 23€
- Jumeau Pomerain - 4€
- Jumeau Pomerain - 18€
- Spirit Jumeau de la Pige Pomerain - 44€
- Cuvée Jumeau 100% Jumeau - 33€
- Cuvée Jumeau 100% Espale - 25€
- Pomerain - 18€

STAMPING CLUB







ZIRKOL | ROUND

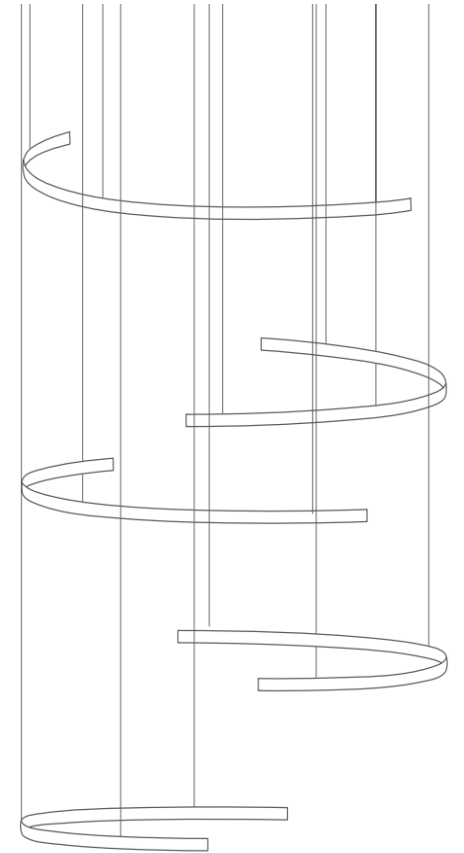



Custom solutions

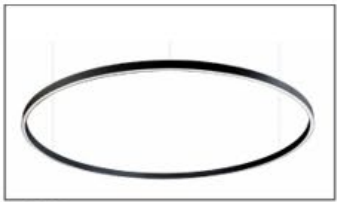

ref. ZC
ZIRKOL RA 2-1,5-1,25-1-0,75-0,5-0,4 mt.

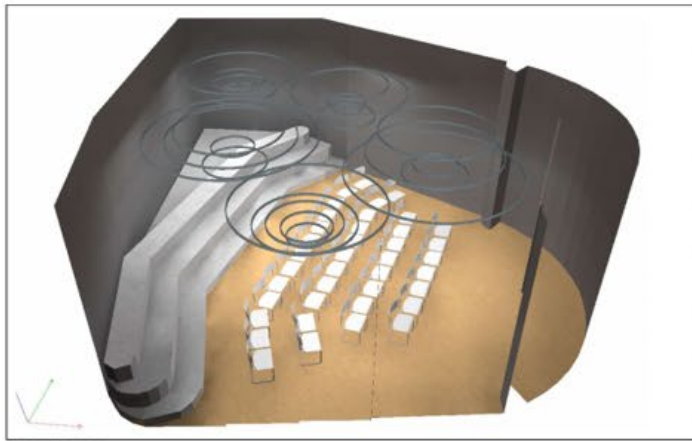

3D VIEW

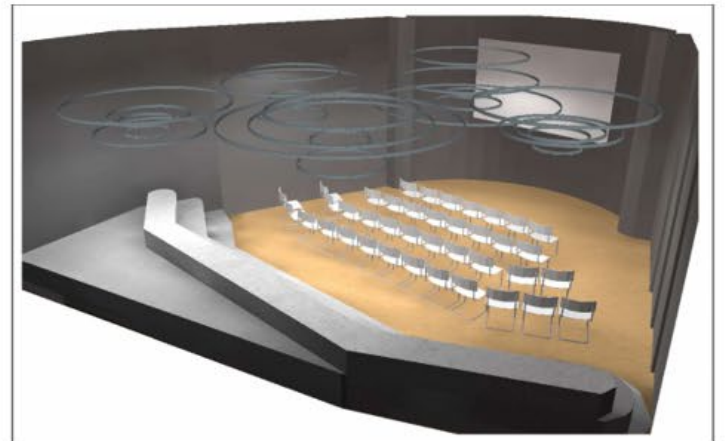

3D VIEW

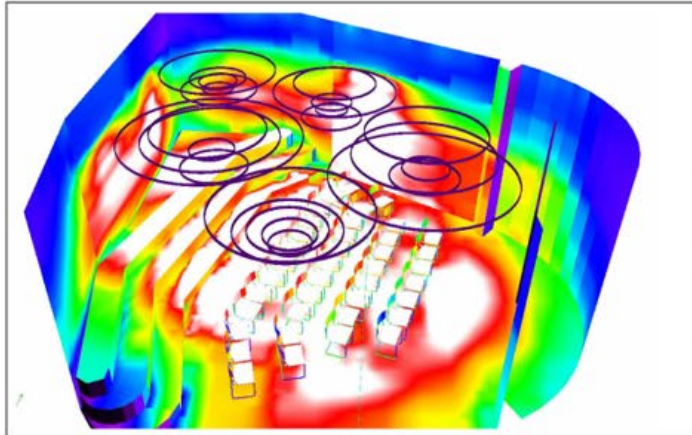
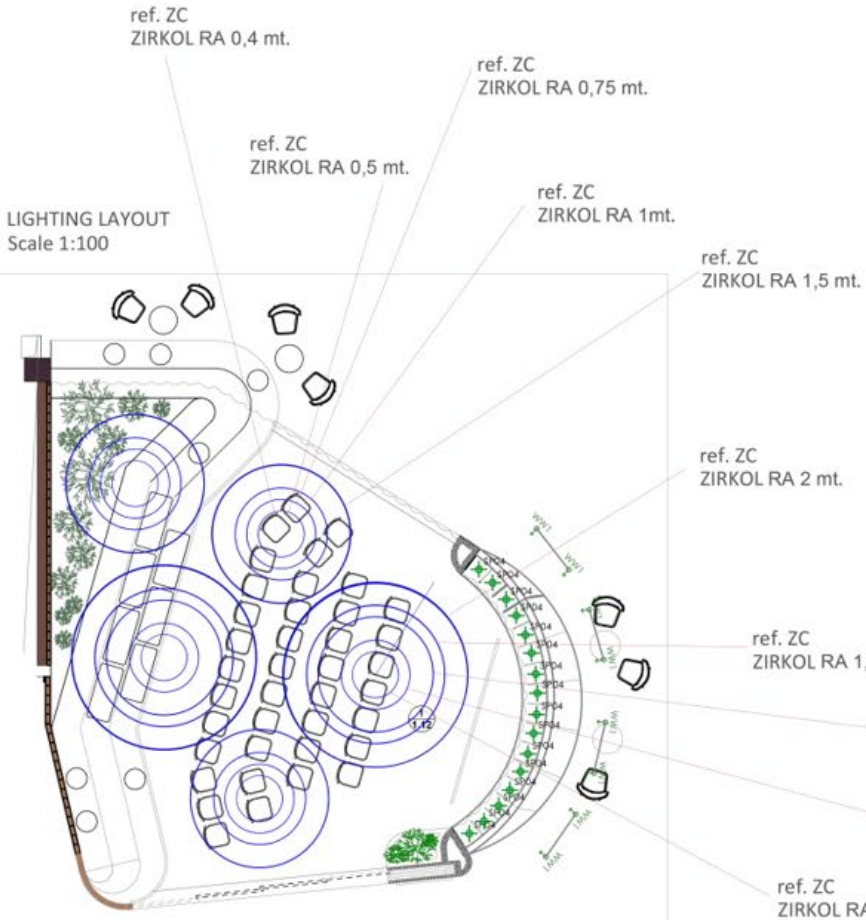

3D VIEW FALSE COLORS

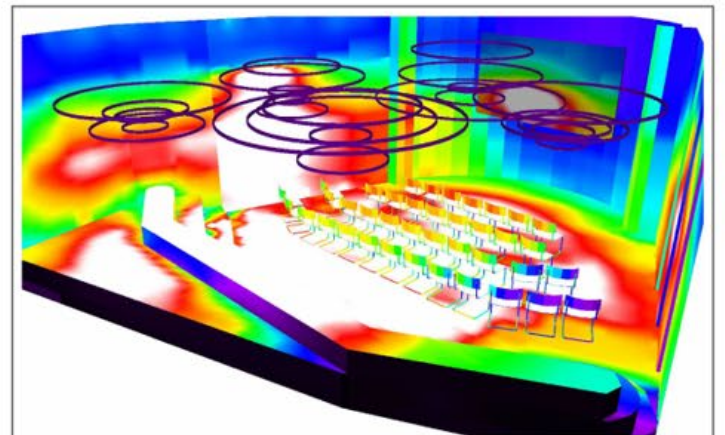

3D VIEW FALSE COLORS



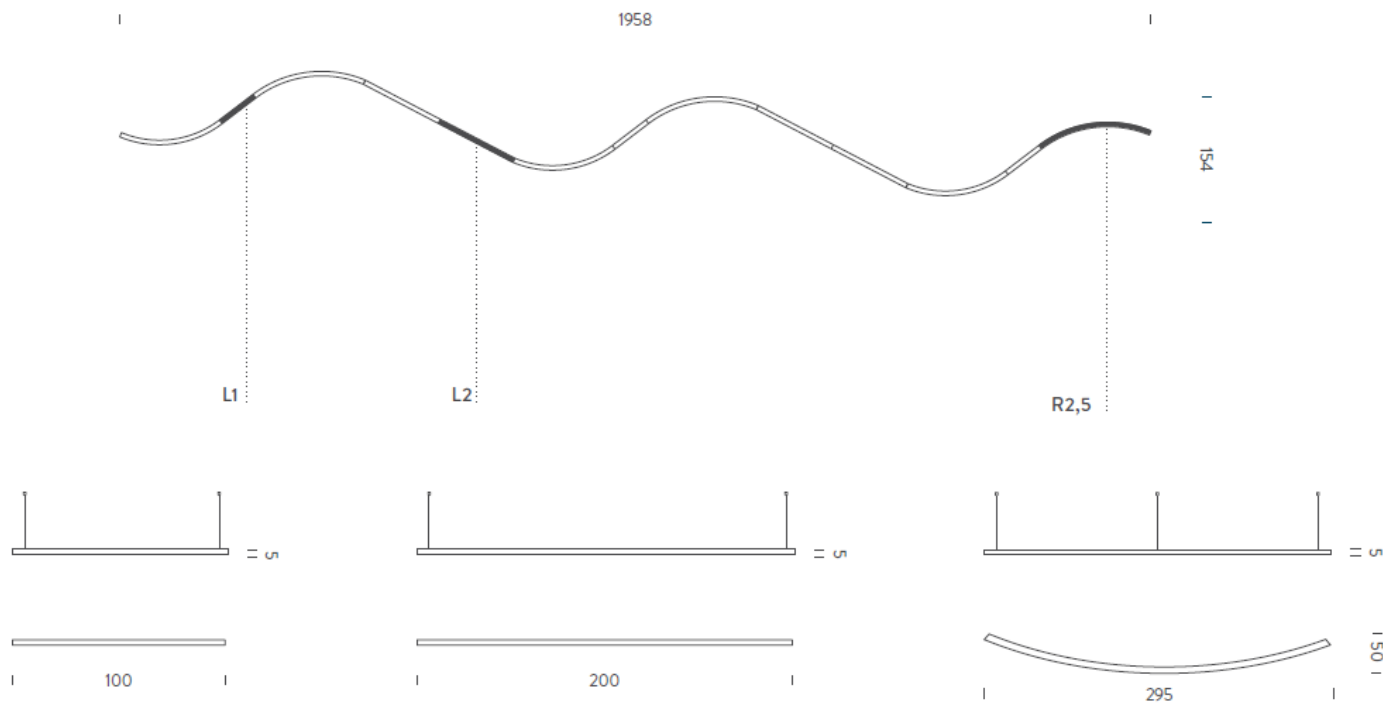



ZIRKOL SIZE CHART

CUSTOMIZATION



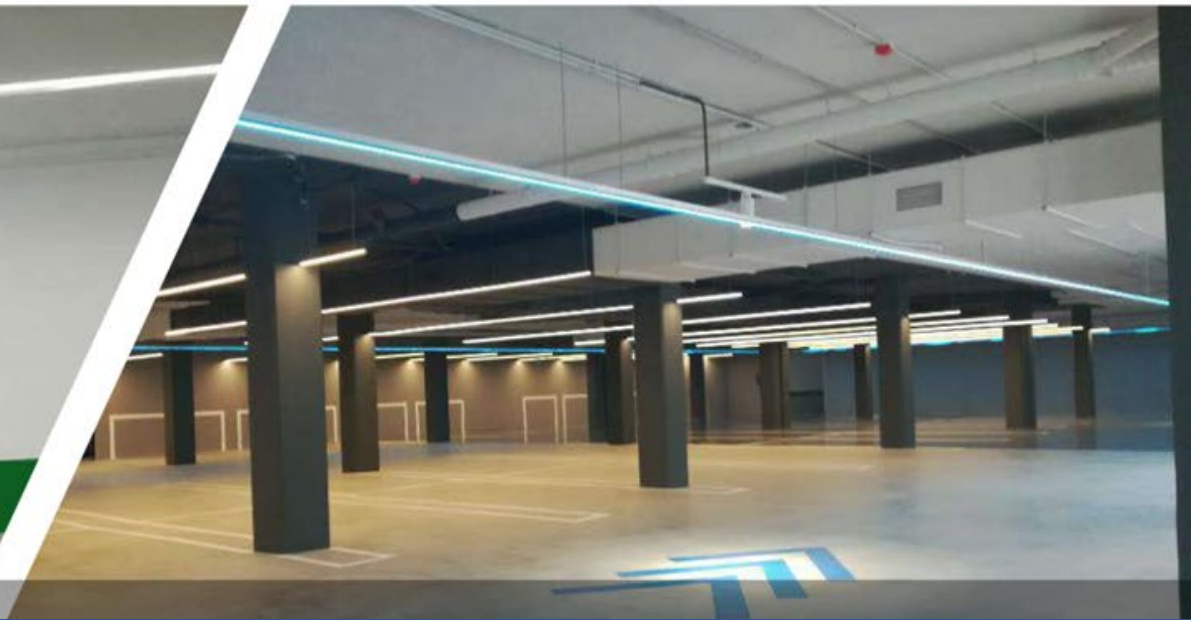















LBB01

Lina Bo Bardi

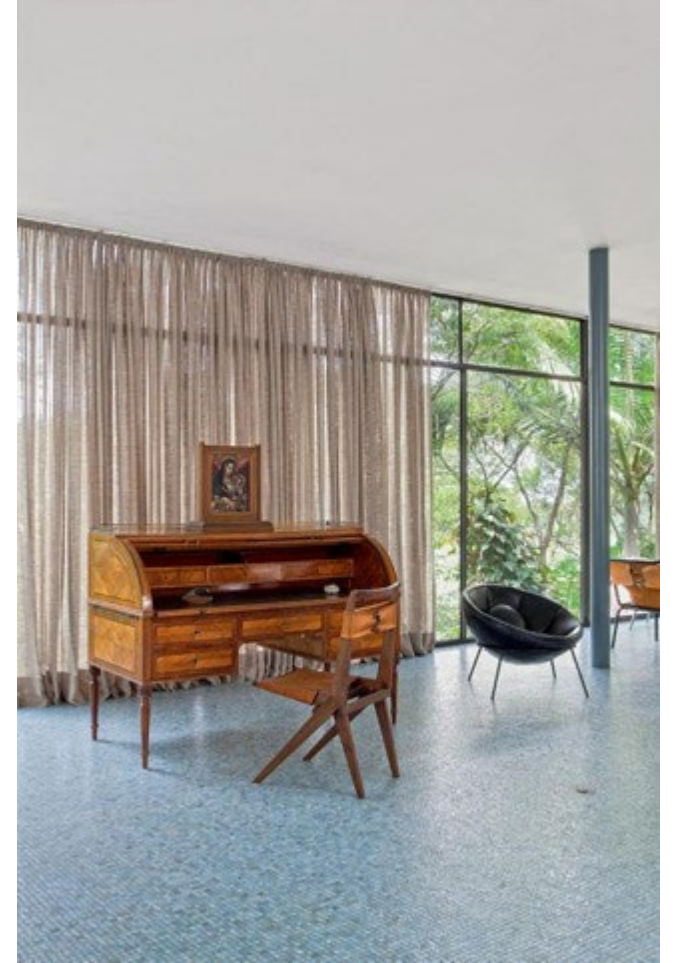







TUBES

Charles Kalpankian

TUBES 3 Pendant

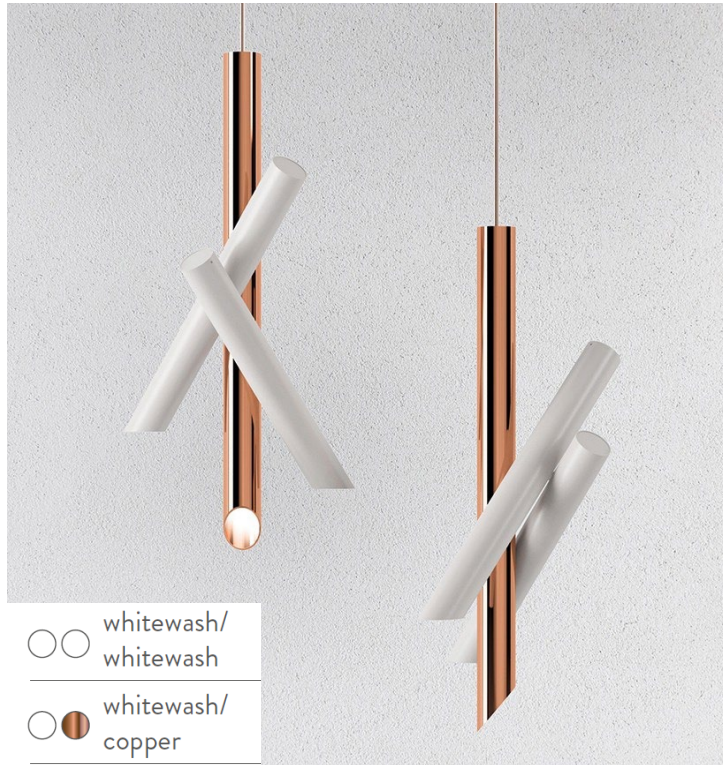

● ● black/black

TUBES 2 wall/ceiling



● black

TUBES Large wall/ceiling





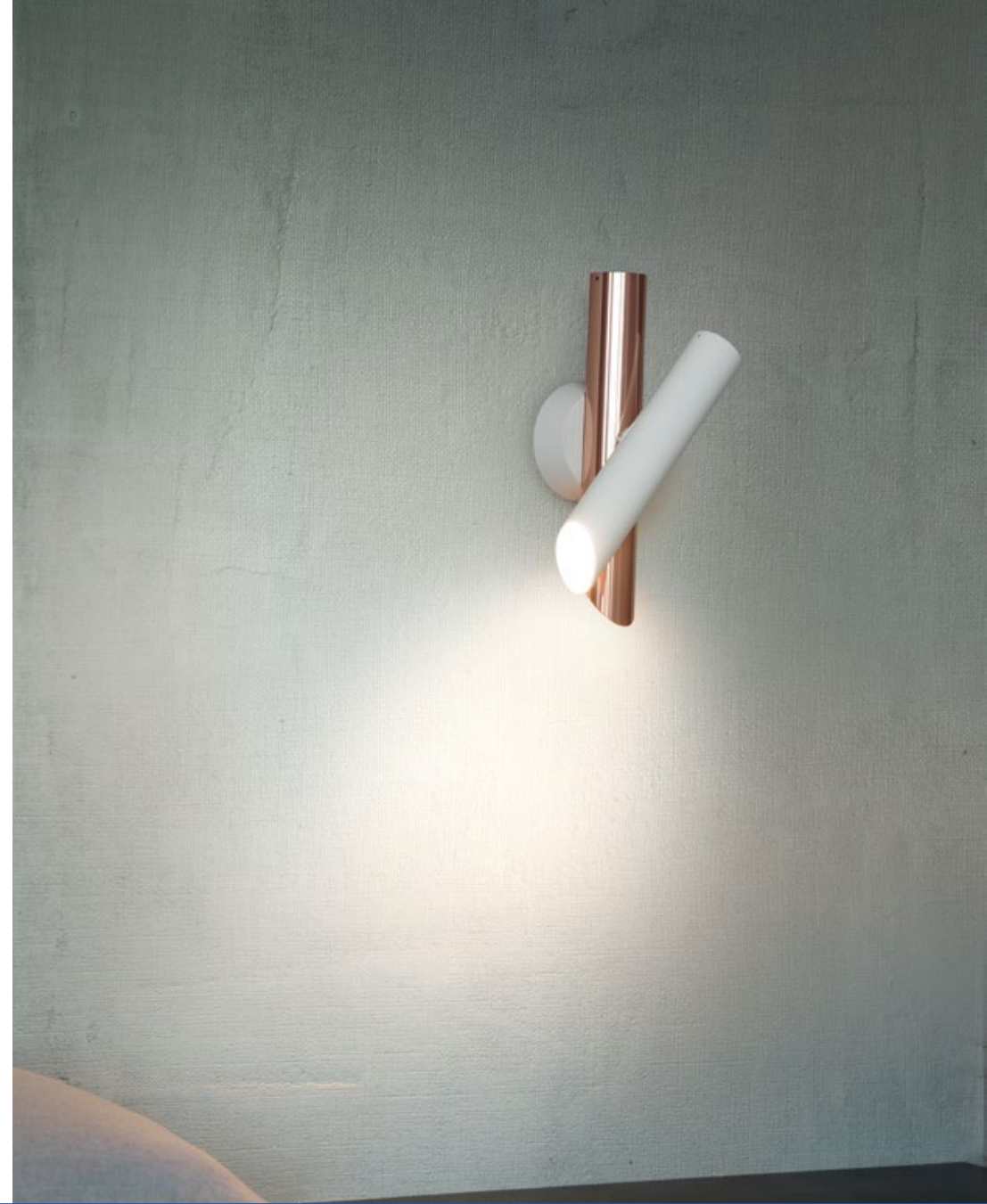





FLOOR LAMPS

FOX

Bernhard Osann

NEMO

FOX

Sorgente: **LED board**
Total power: **13W**
Luminous flux: **767lm** (to be confirmed)
Emission: **orientable**
Switching: **dimnable**
Color temperature: **2700K**
Tension: **110/240V**
Typ cri: **90**
Notes: **cable length 3,5m, dimmer on cable**

Code: **FOXLN221 - black textured**

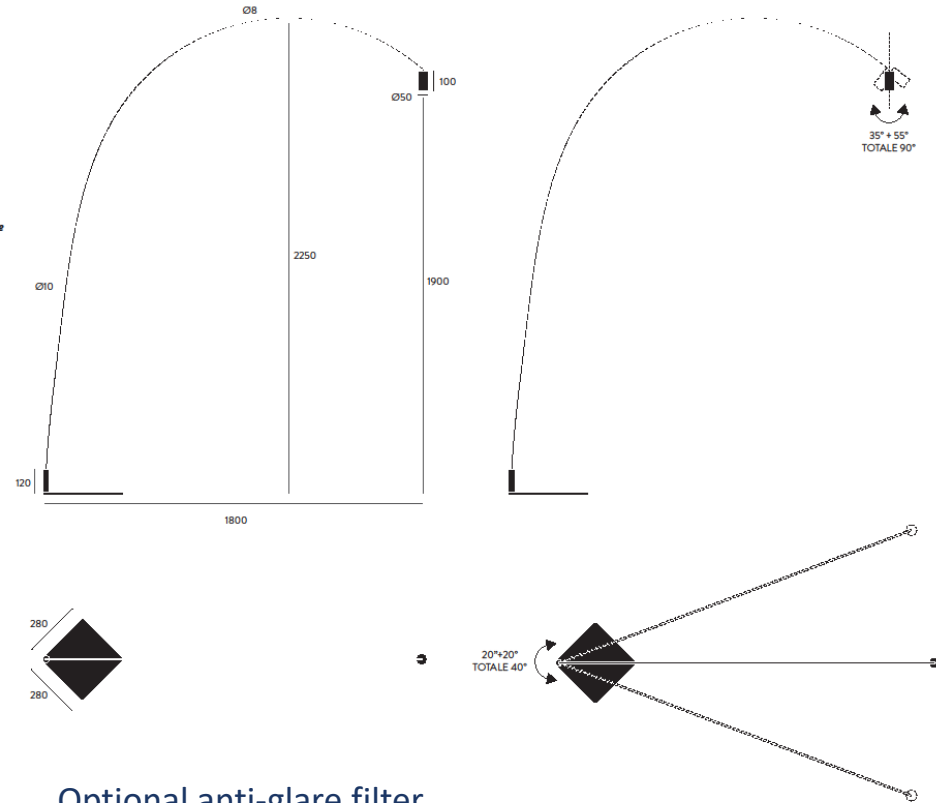

Optional anti-glare filter



FOX

Bernhard Osann



FOX

Bernhard Osann

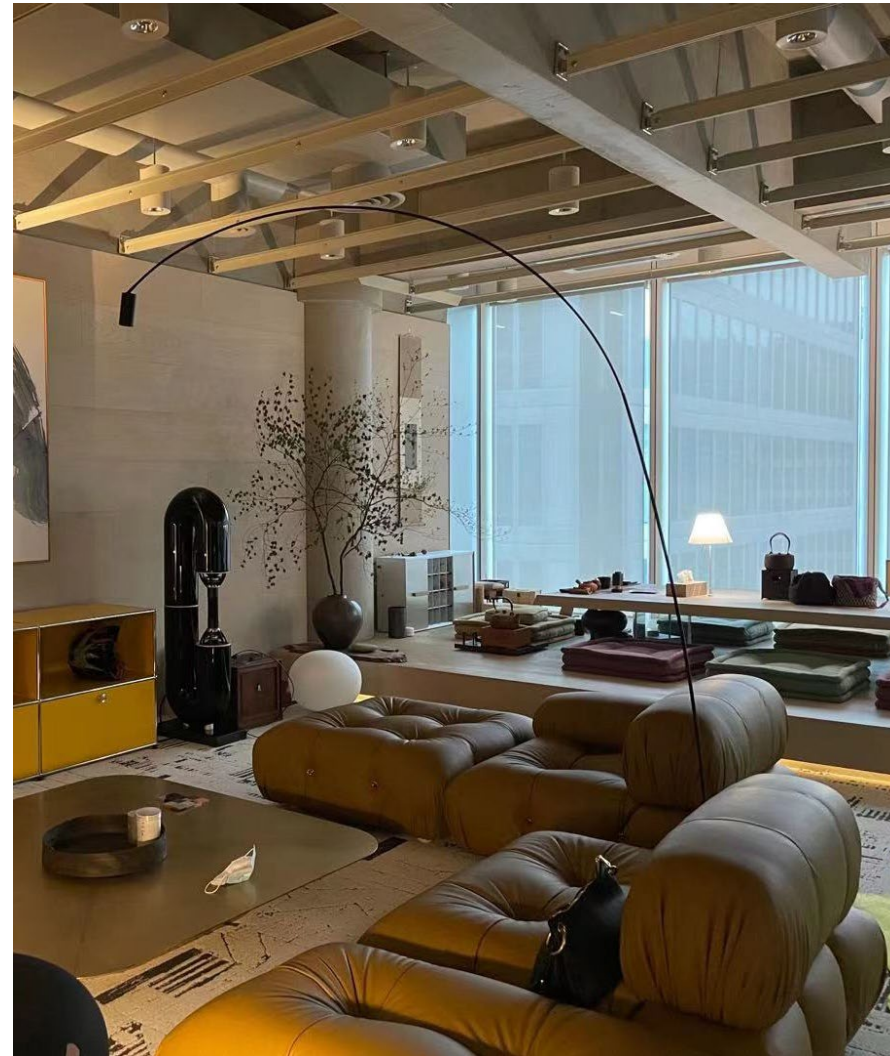
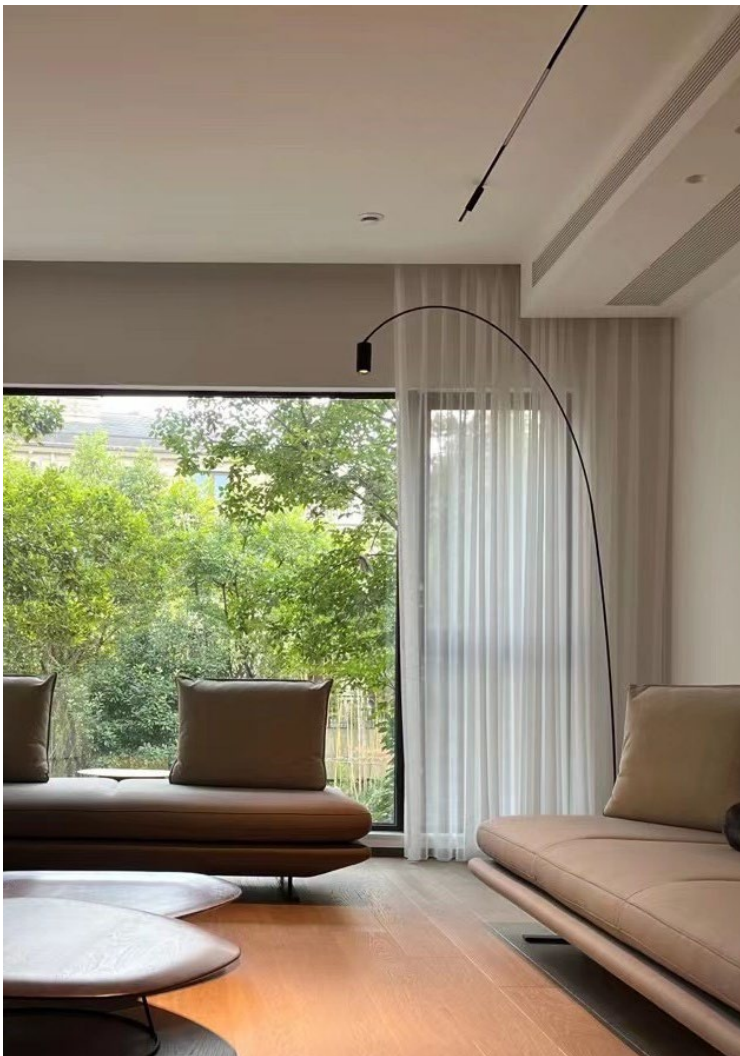





FOX WALL

Bernhard Osann



NEO

Berhard Osann



● black

● gold

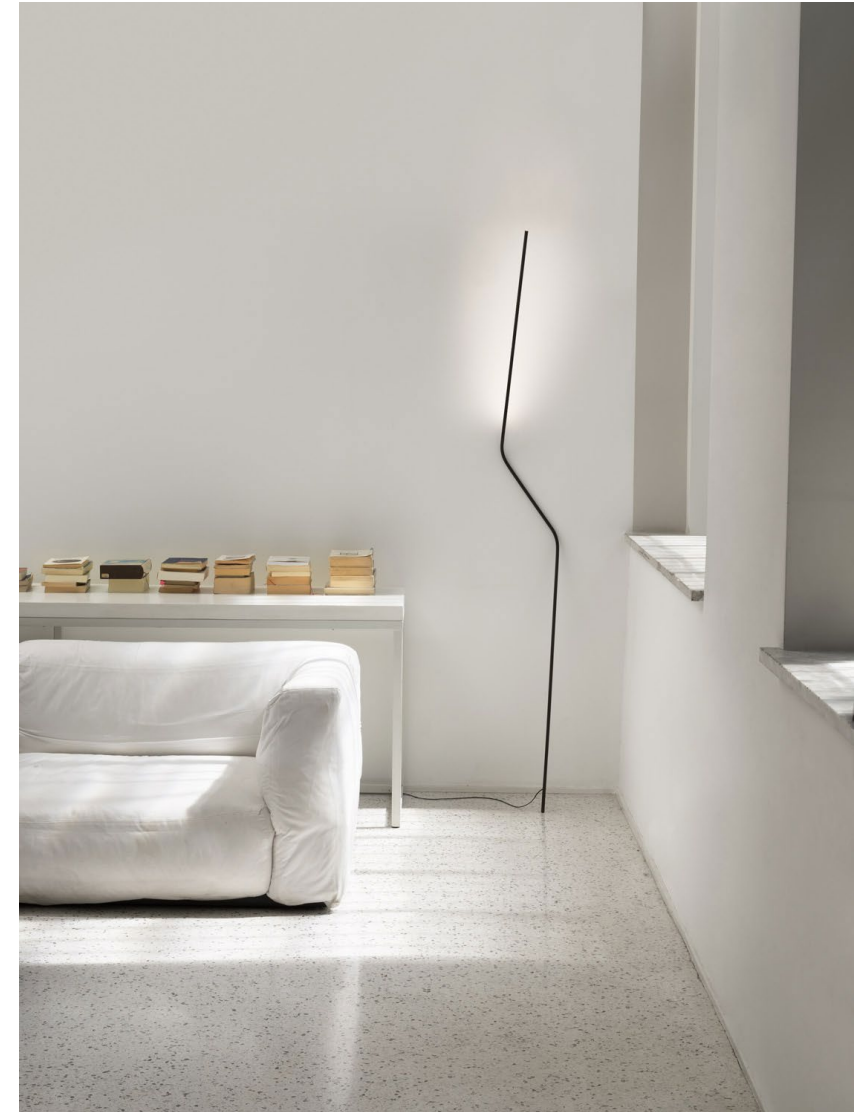

TRU Floor

Roberto Paoli



white

black

titan grey

TRU Floor

Roberto Paoli



ARA DTW

Ilaria Marelli

○ ○ white/white

● ● anthracite/
anthracite

● ○ champagne/
polished

● ○ anthracite/
polished

● ○ moka/polished

Piero Lissoni Design 2022





340° rotation



Dim to warm control on board



Top led board

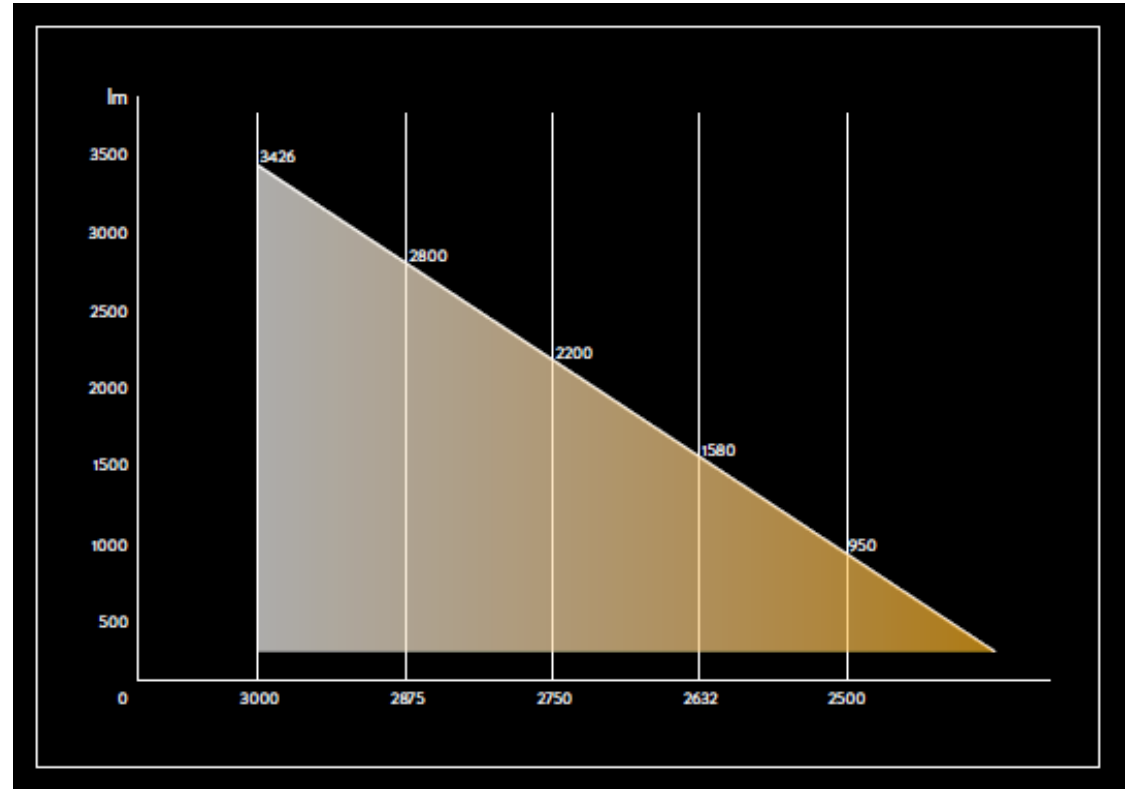

PLINT

Massimo Colagrande



Zoom Optic

LED spot

● black

○ white

● gold

● grey



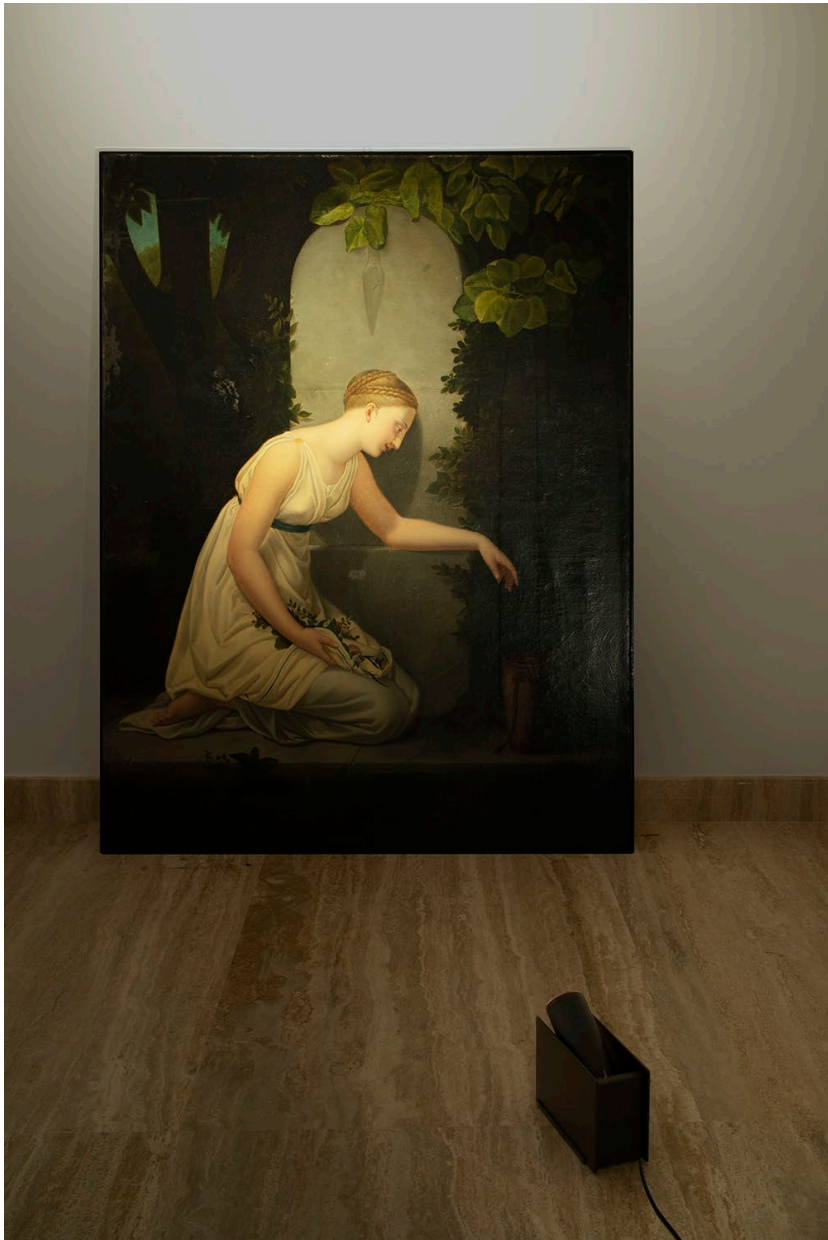



Vertical

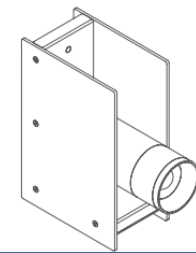
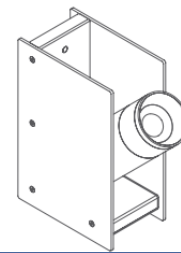
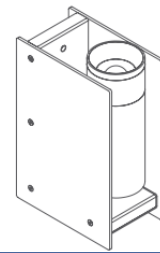

TYPE

Guillaume Bloget

360° magnetic rotation

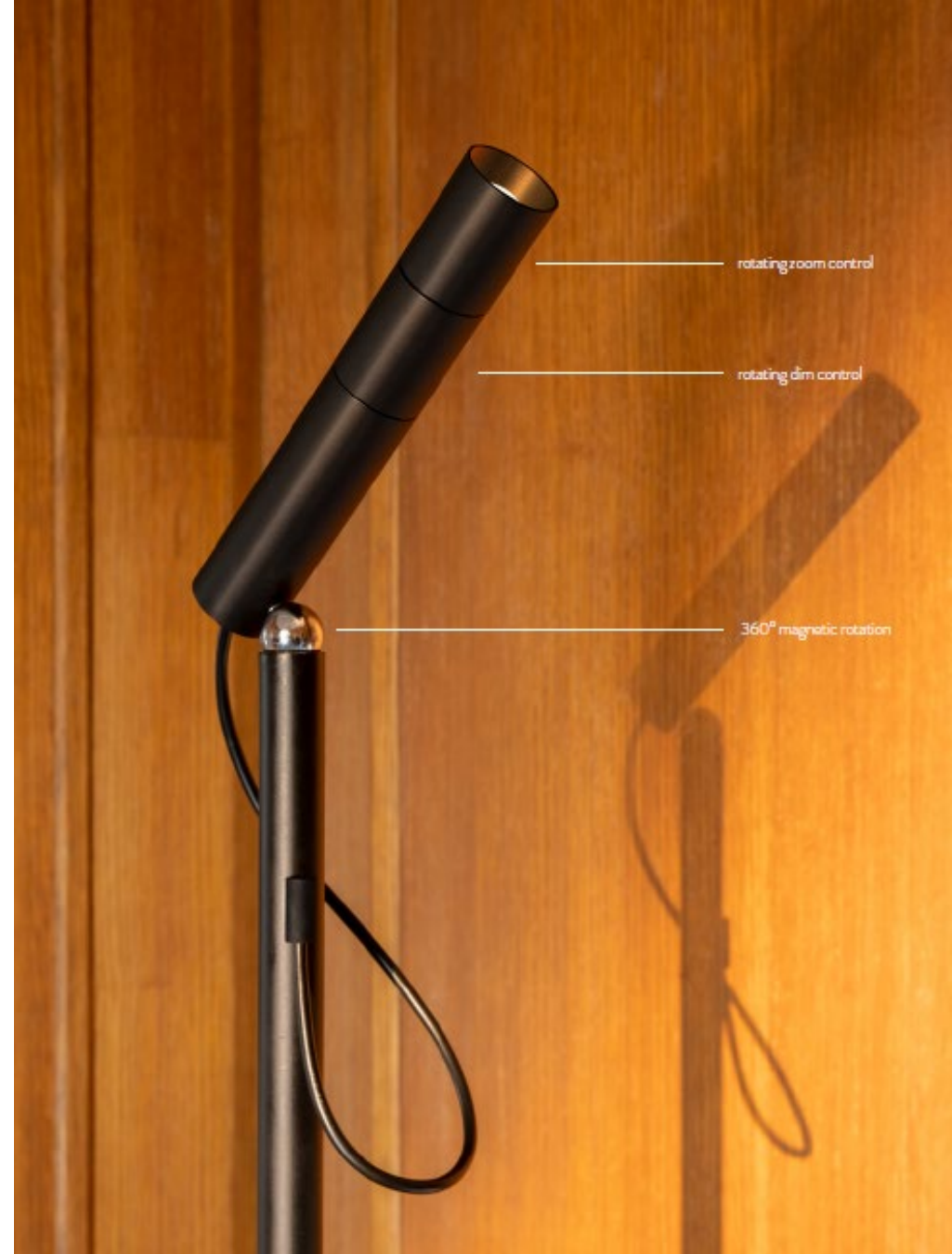
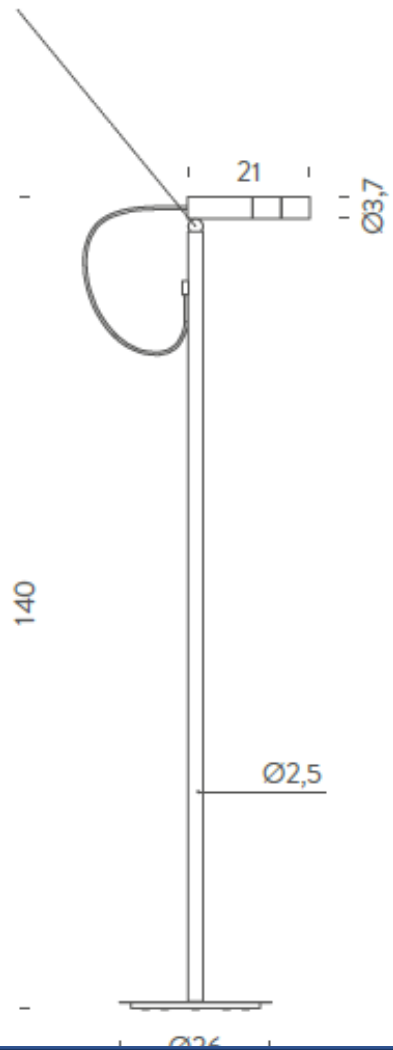

rotating zoom control

rotating dim control

360° magnetic rotation

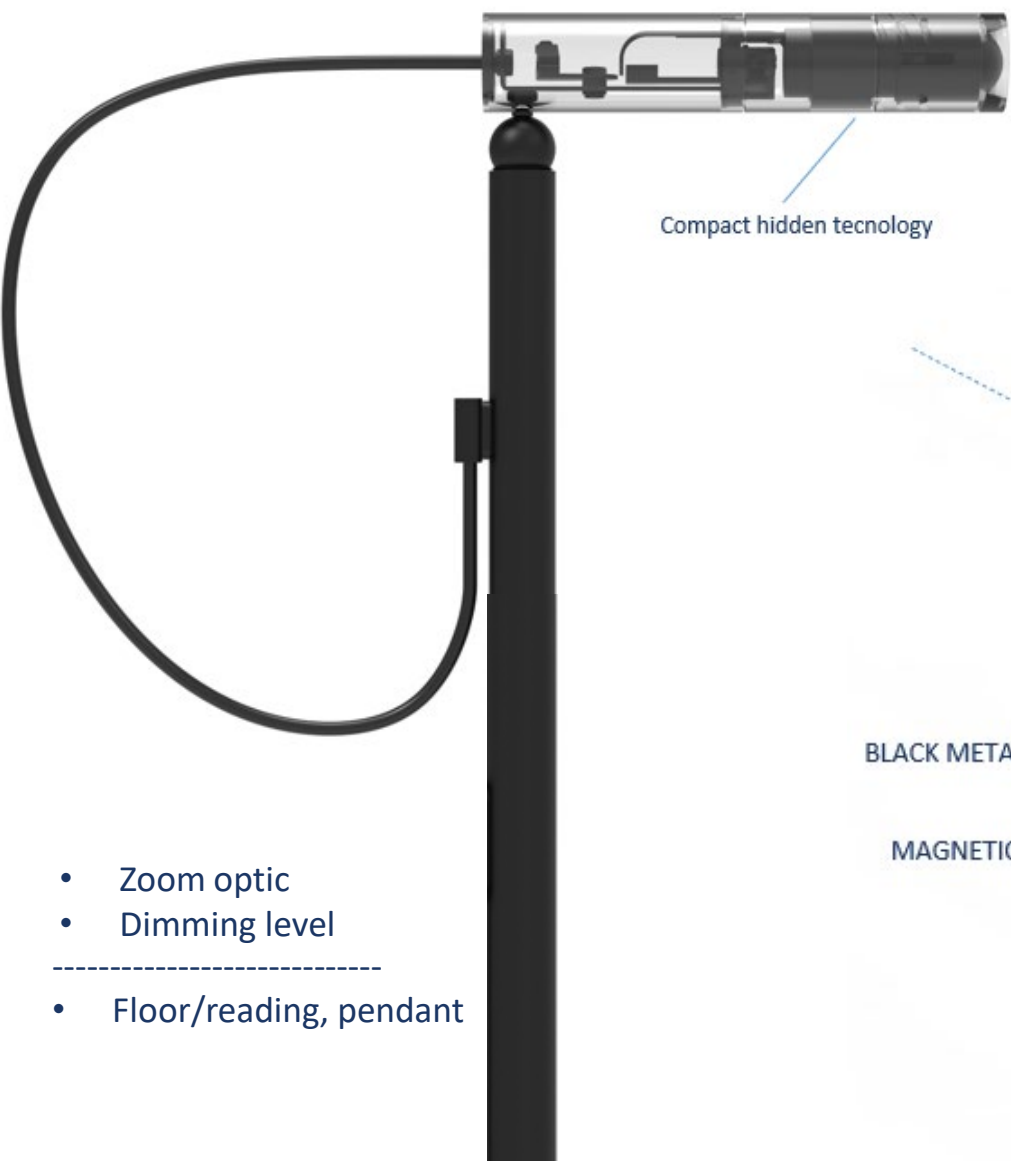

Compact hidden tecnologia

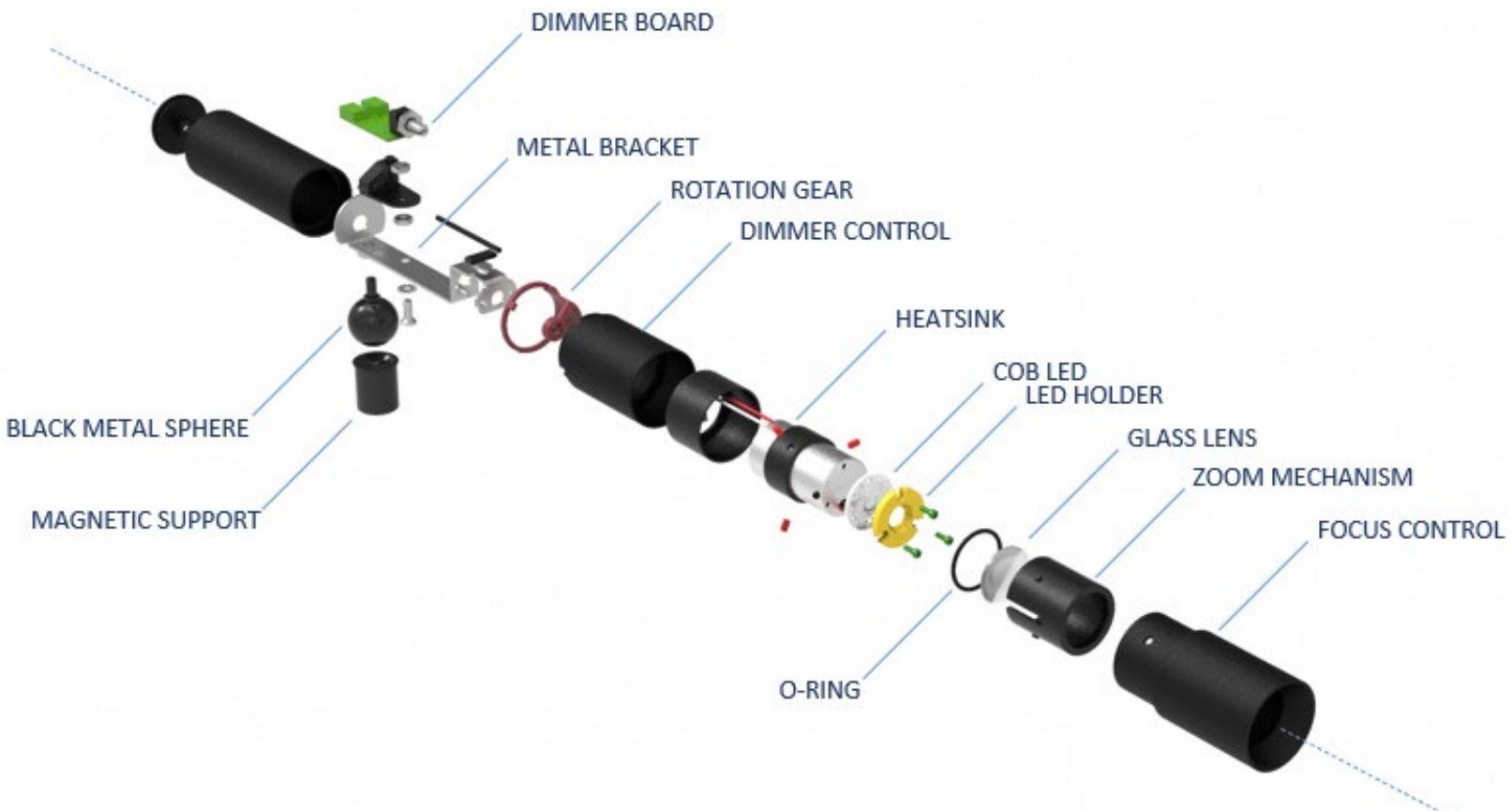

- Zoom optic
- Dimming level

- Floor/reading, pendant

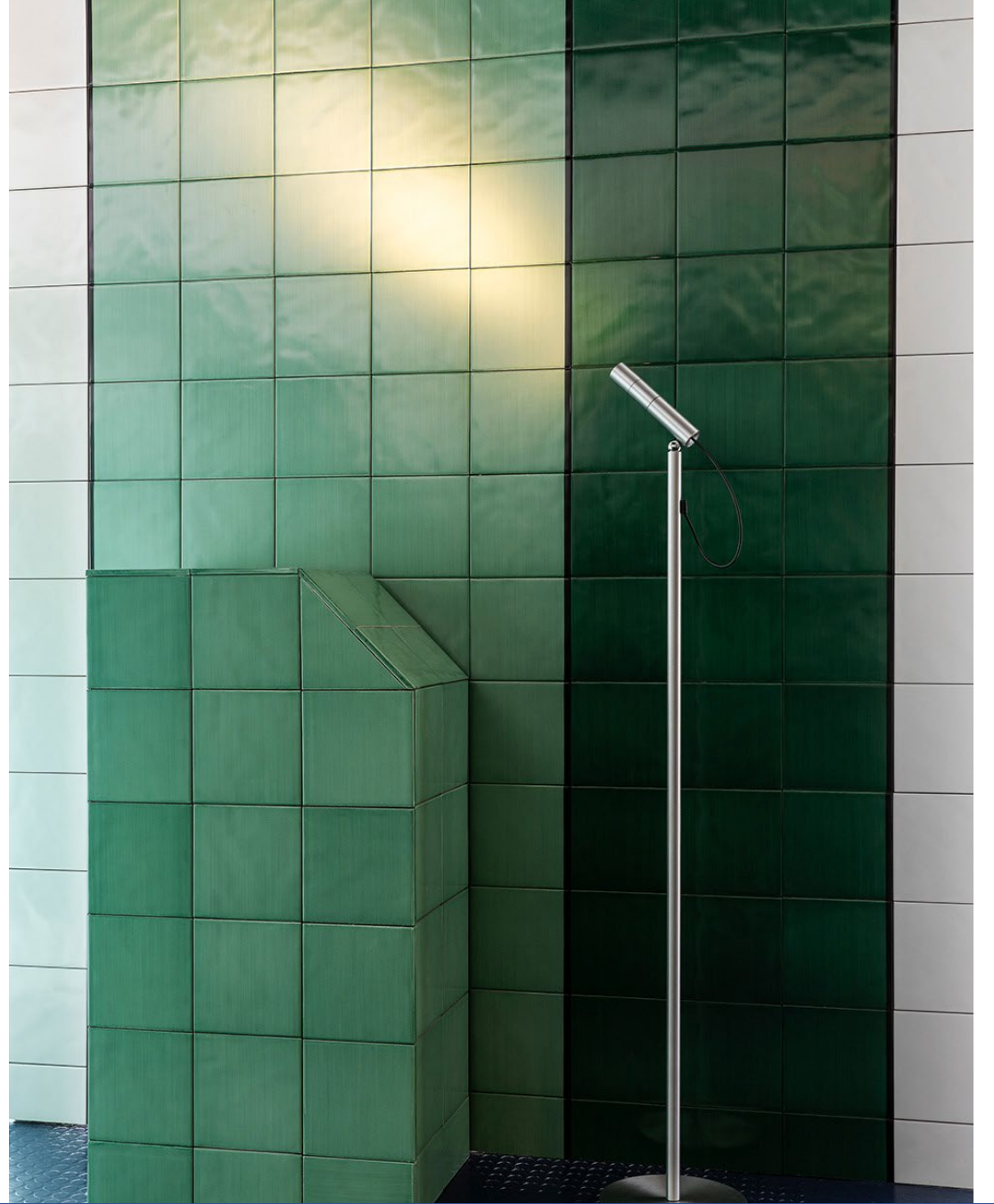

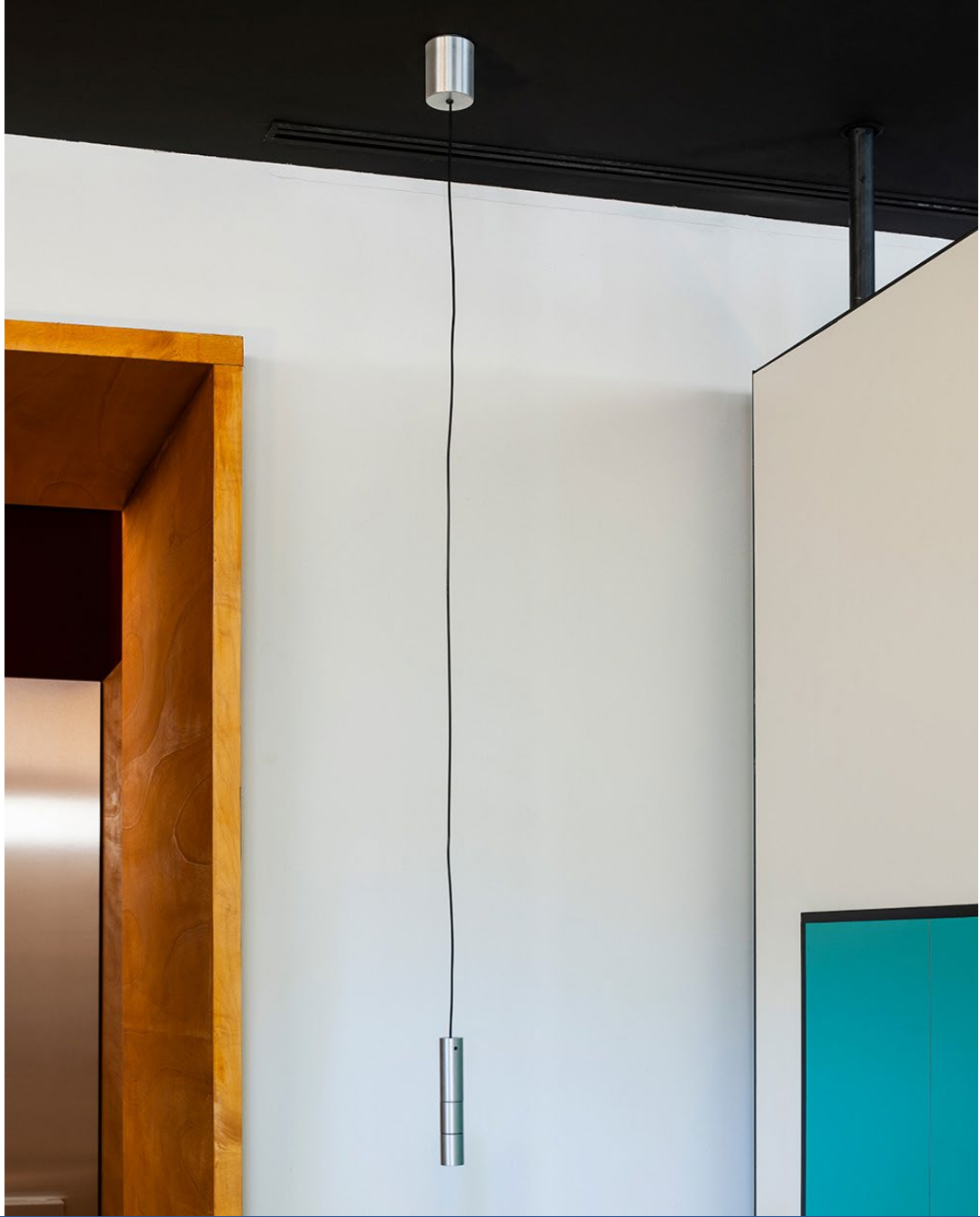

TABLE LAMPS



UNTITLED

Bernhard Osann

- Mini
 - Table or wall
 - Reading
-
- Linear or spot
 - Reading: cone/gold

UNTITLED

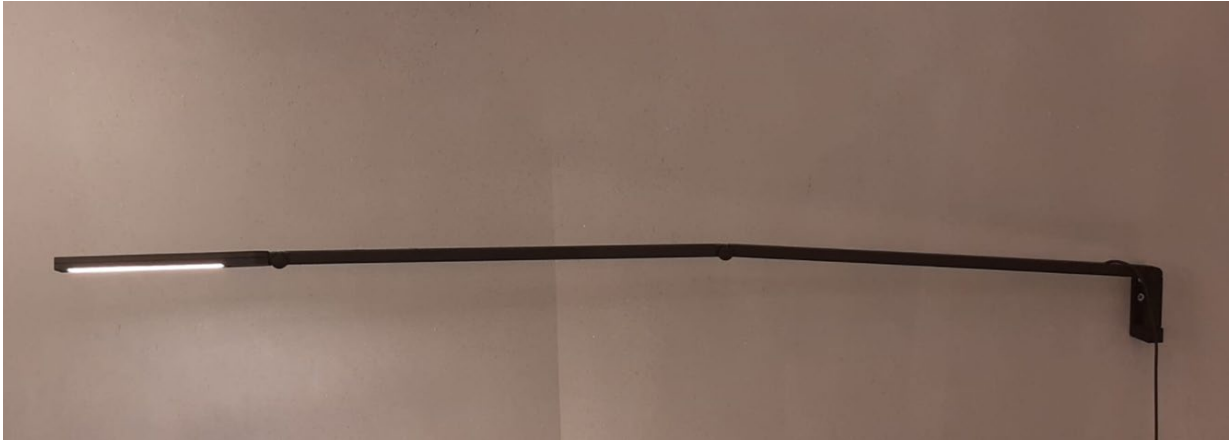
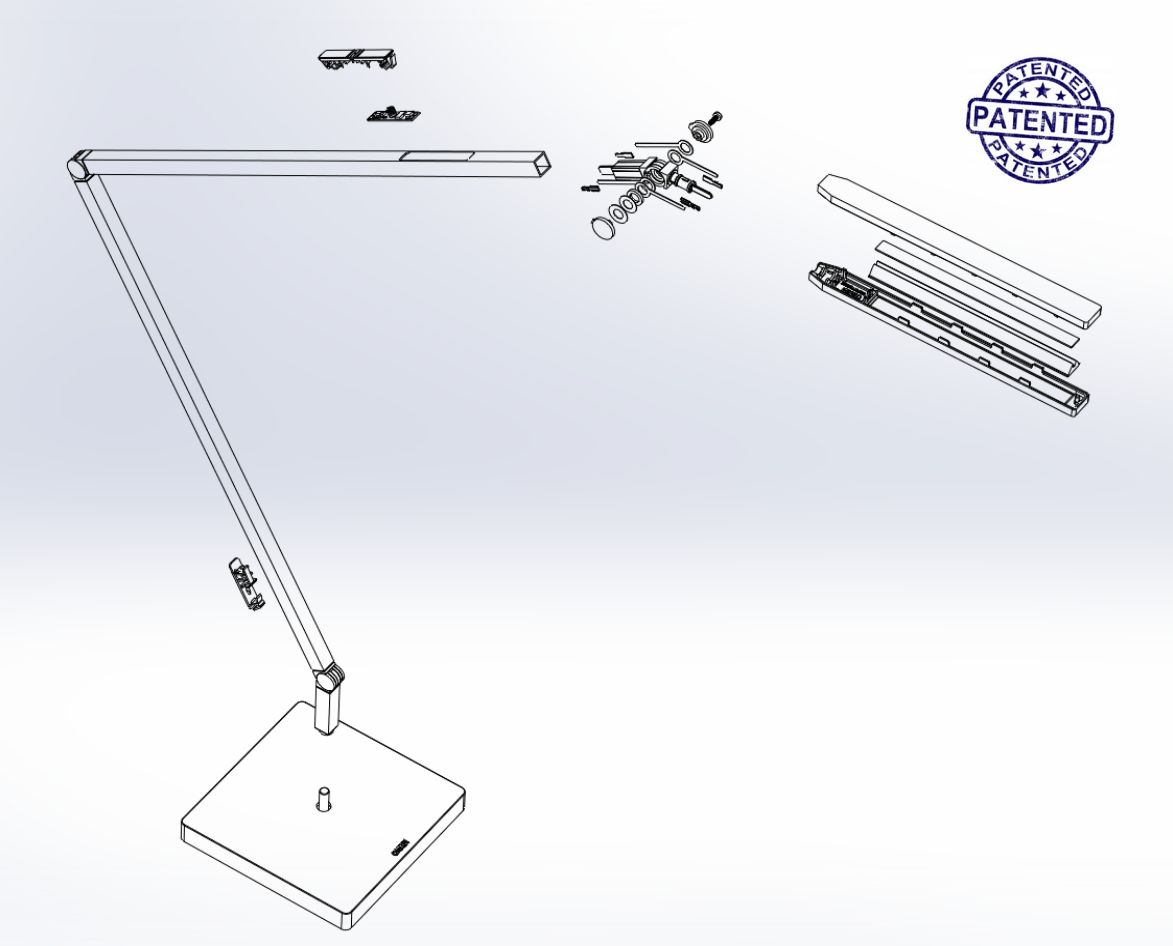

UNTITLED Accessories

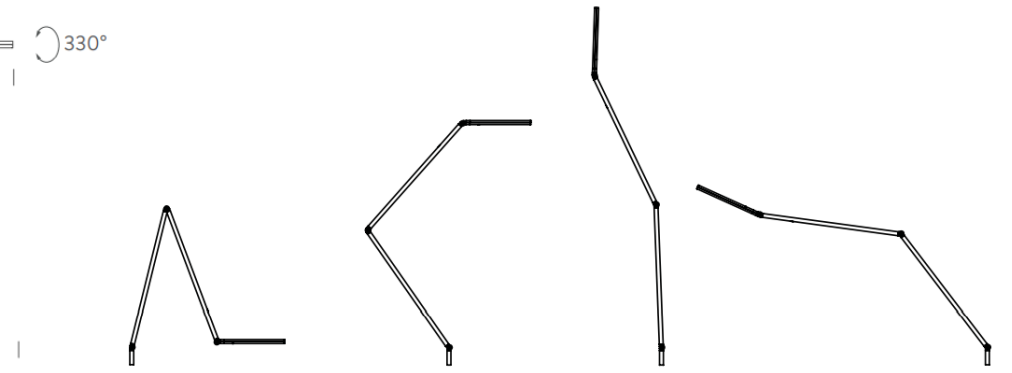
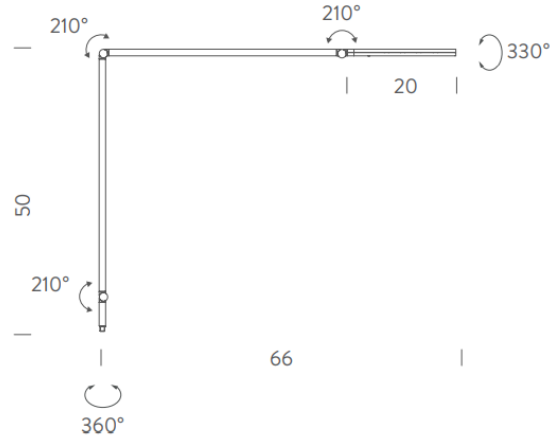
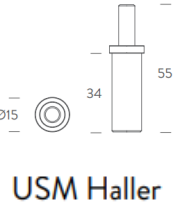
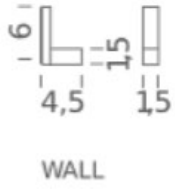
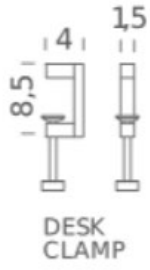







Linear light source for glare-free illumination
of the desk (UGR Index respected)



LINEAR



SPOT



UNTITLED READING

Berhard Osann

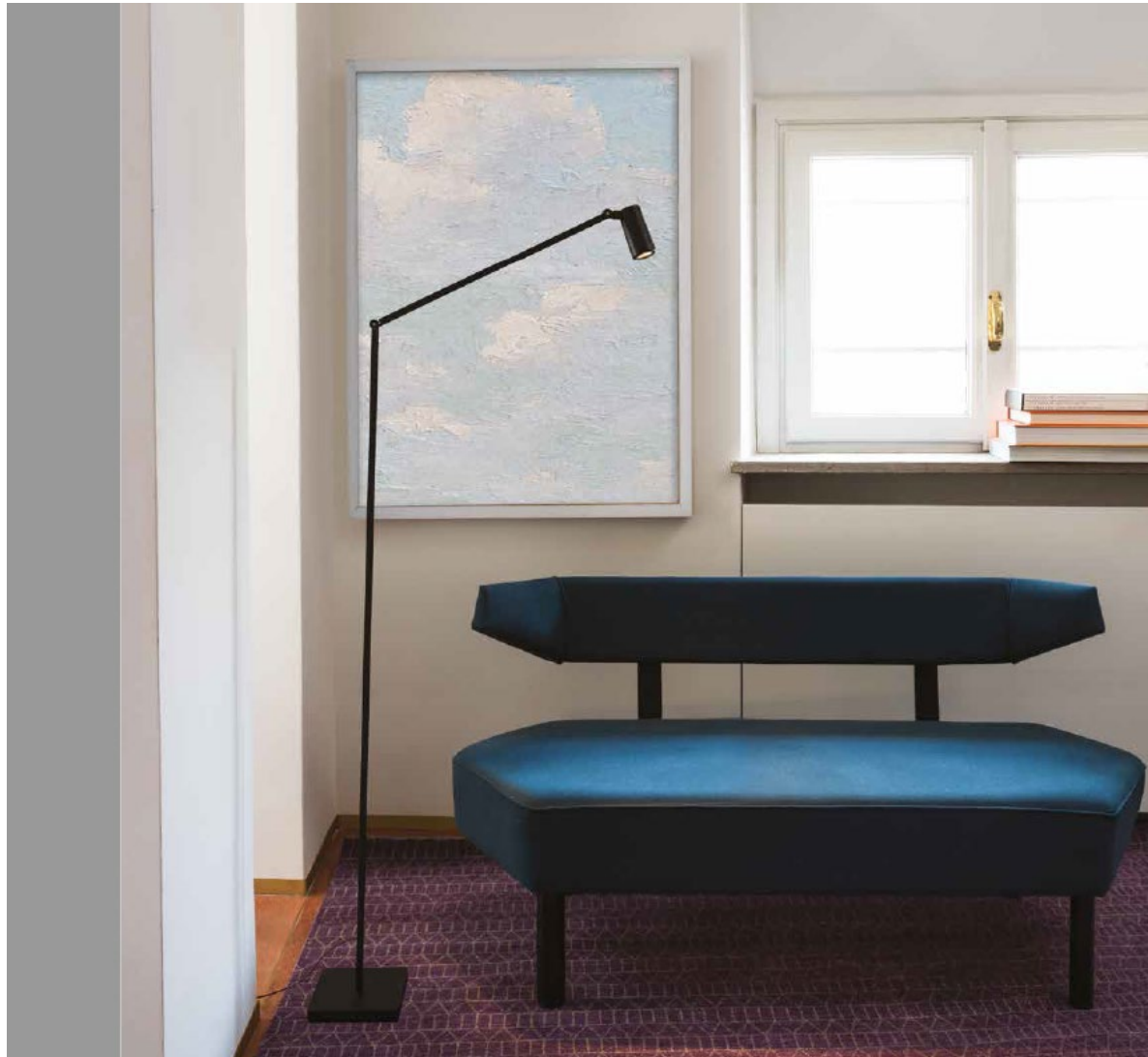

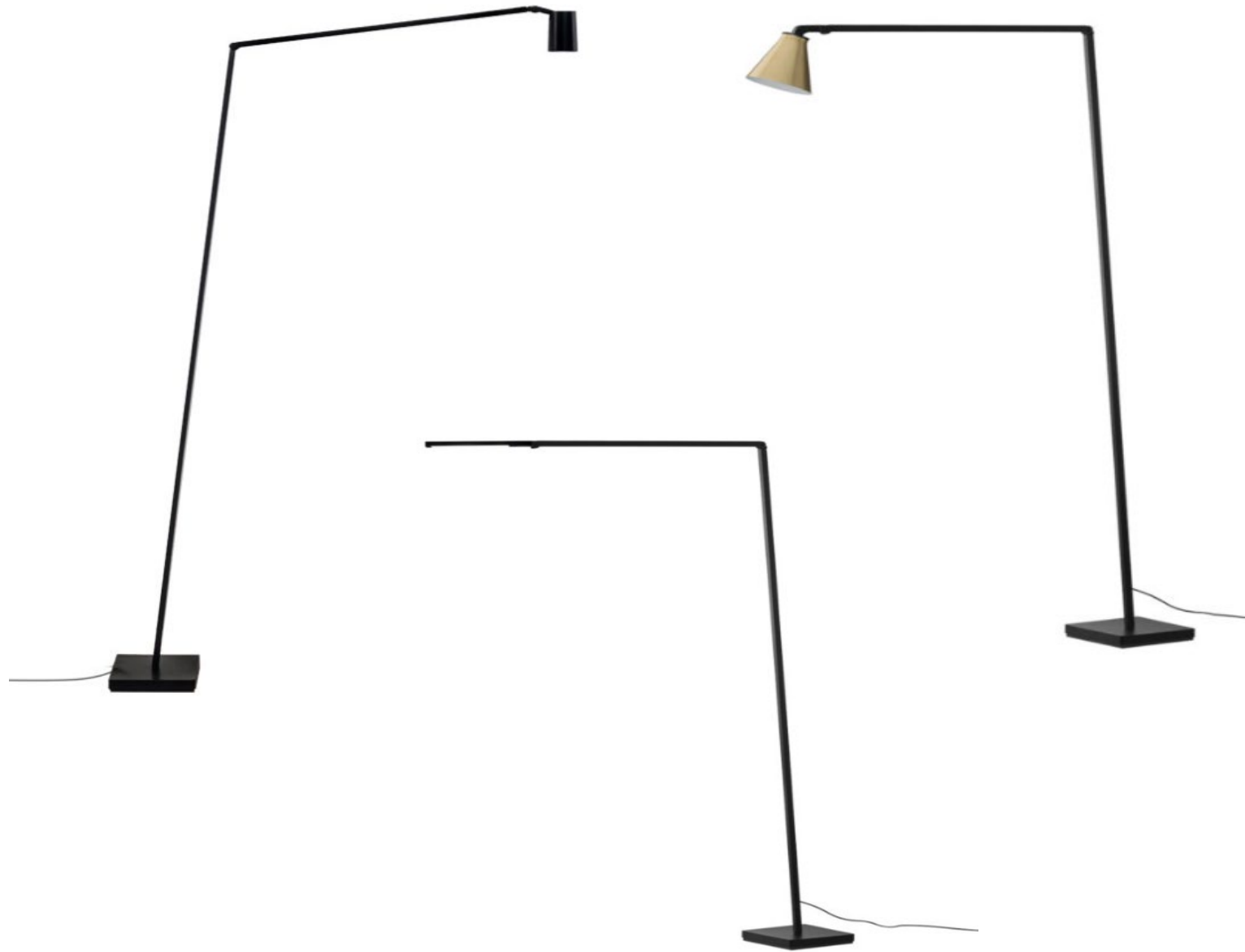

UNTITLED MINI Linear



UNTITLED MINI Spot



PORTOFINO

Valerio Sommella



- Three dimming levels

Portofino finishes

STANDARD

Matte white



Matte black



Blue Portofino



Emerald green



*Matte white
+ Carrara*



*Matte black
+ Black Marquinia*

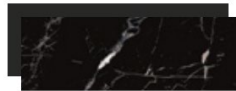

*Blue Portofino
+ Blue Marble*



*Emerald green
+ Green Alpi*





WALL MOUNTED



SWAN

Bernhard Osann





SWAN PLUS



Details

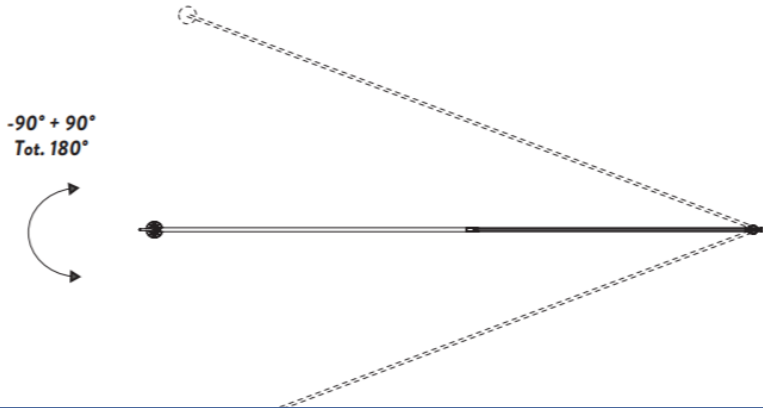
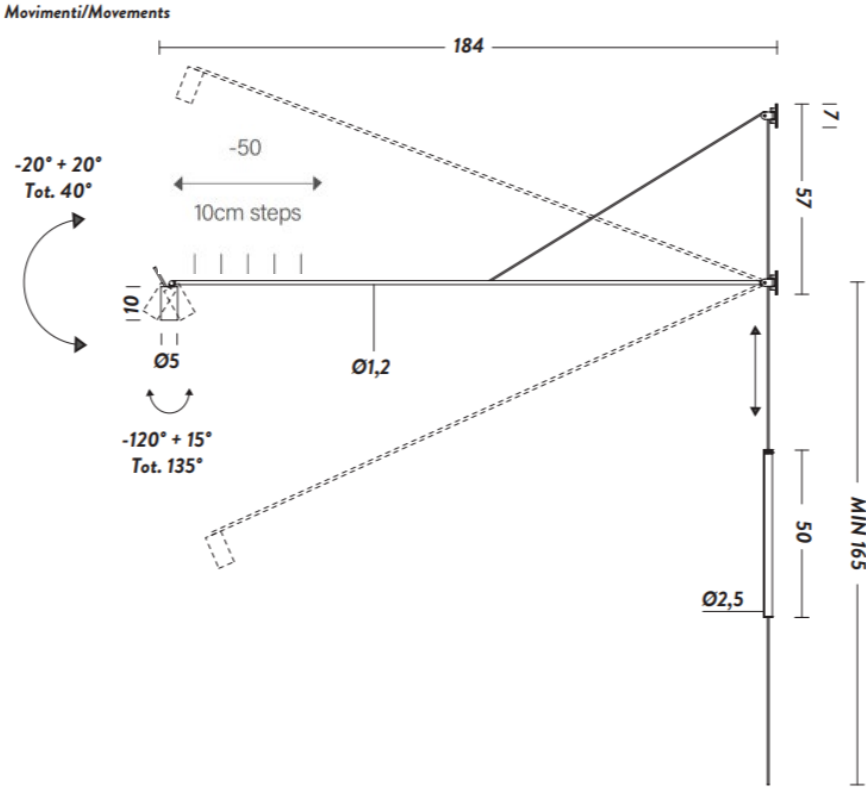





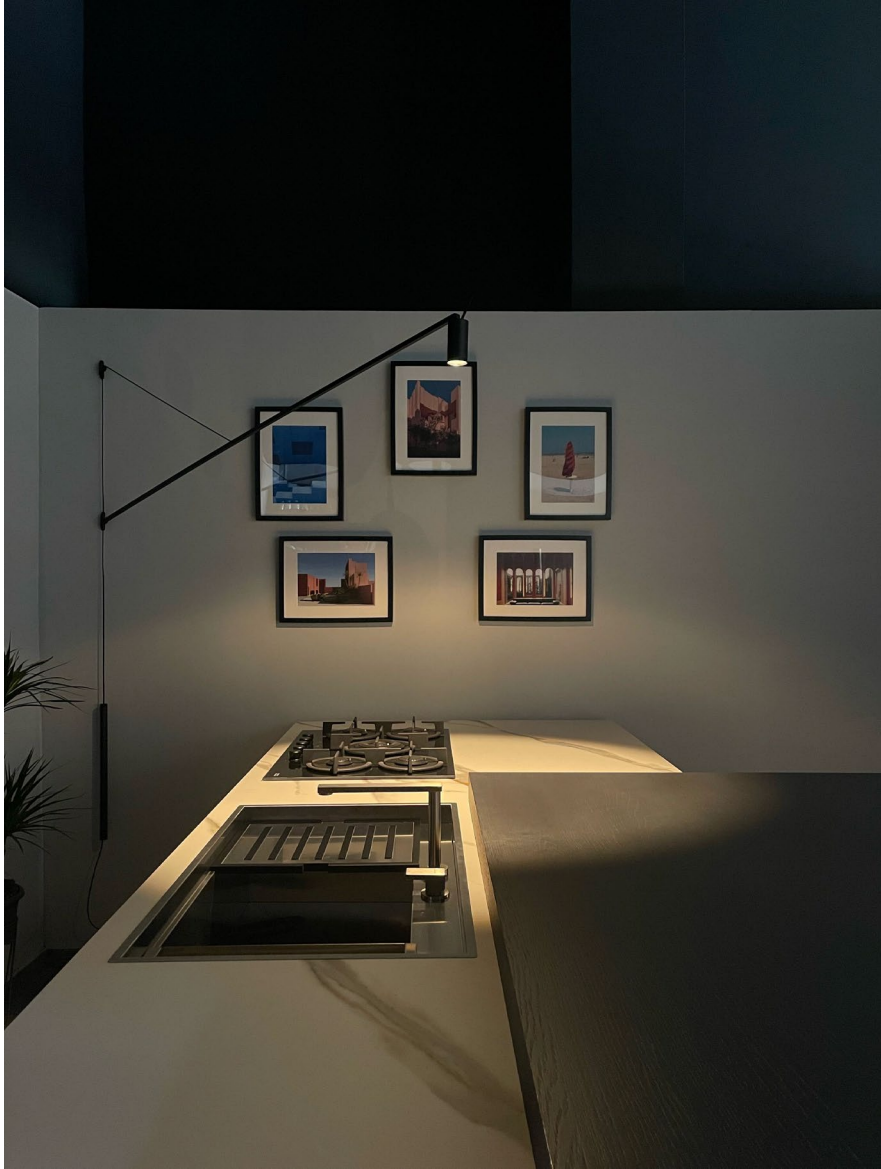

BIRD

Berhard Osann

- Motion-sensing dimmer

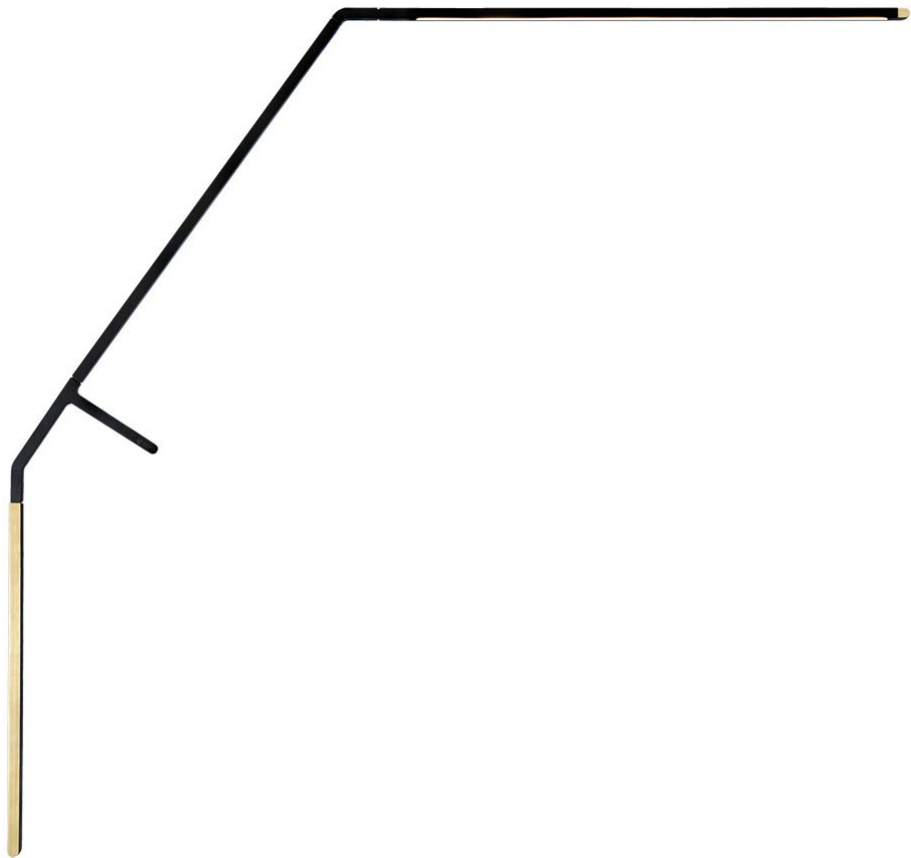

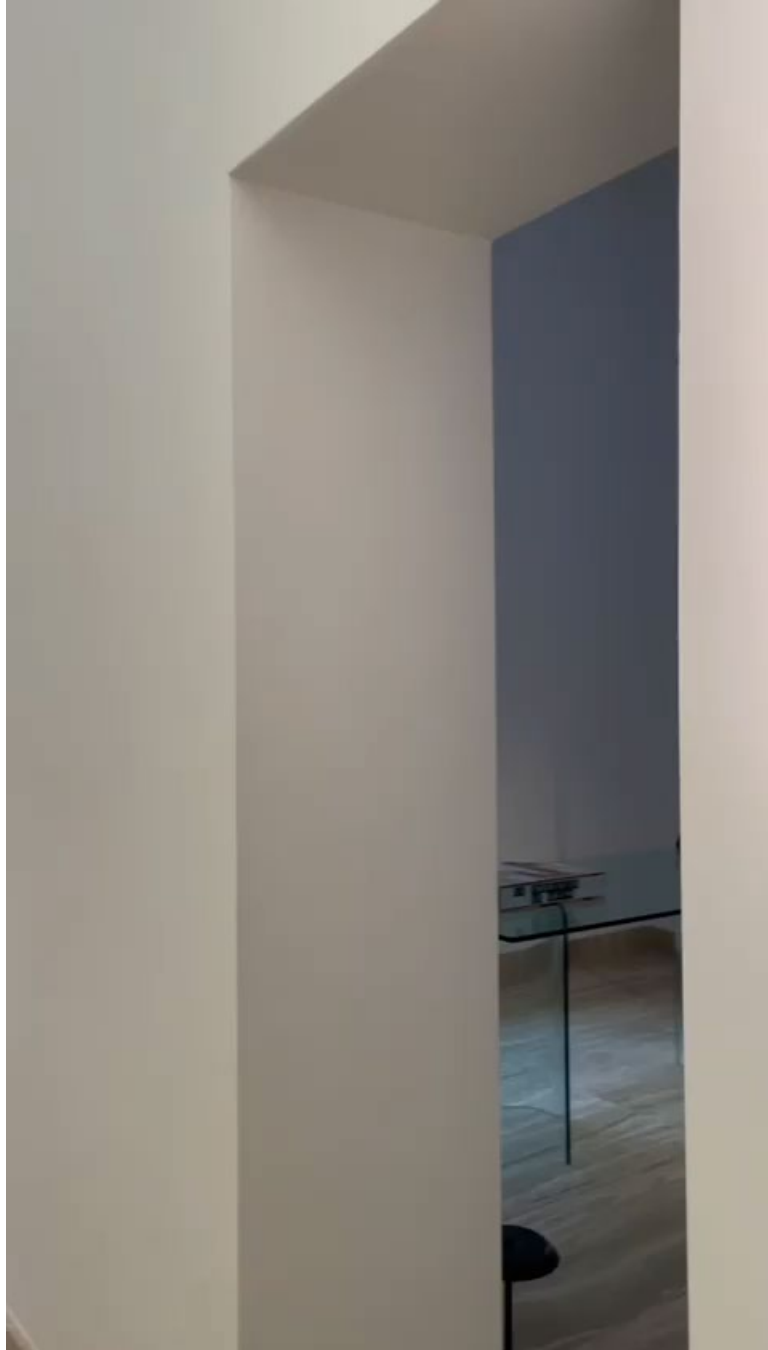





NOTA 1) SUIVRE RIGOREUSEMENT
LE PROFIL.
2) Ce plan annule le même

MASTERS COLLECTION

ATELIER LE CORBUSIER



Lampe de Marseille

Le Corbusier

Pablo Picasso

Le Corbusier

“Our eyes are made to see forms in light; light and shade reveal these forms; cubes, cones, spheres, cylinders or pyramids are the great primary forms which light reveals to advantage; the image of these is distinct and tangible within us without ambiguity. It is for this reason that these are beautiful forms, the most beautiful forms”.

Le Corbusier



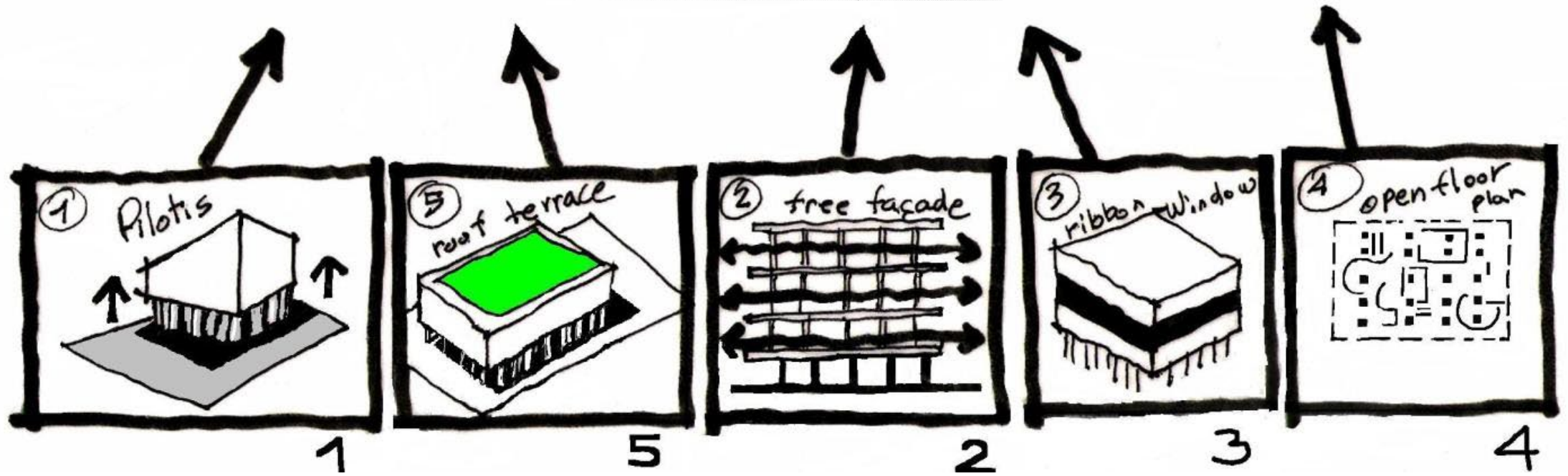
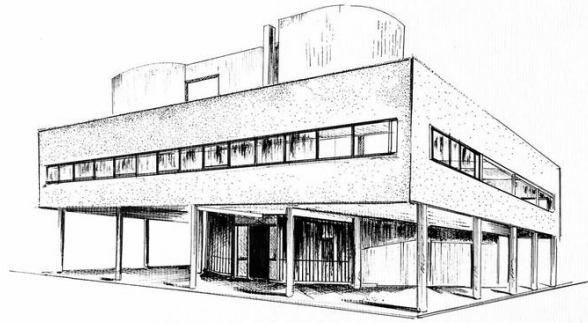

UNITE' D'HABITATION



LAMPE DE MARSEILLE

Le Corbusier 1949-52

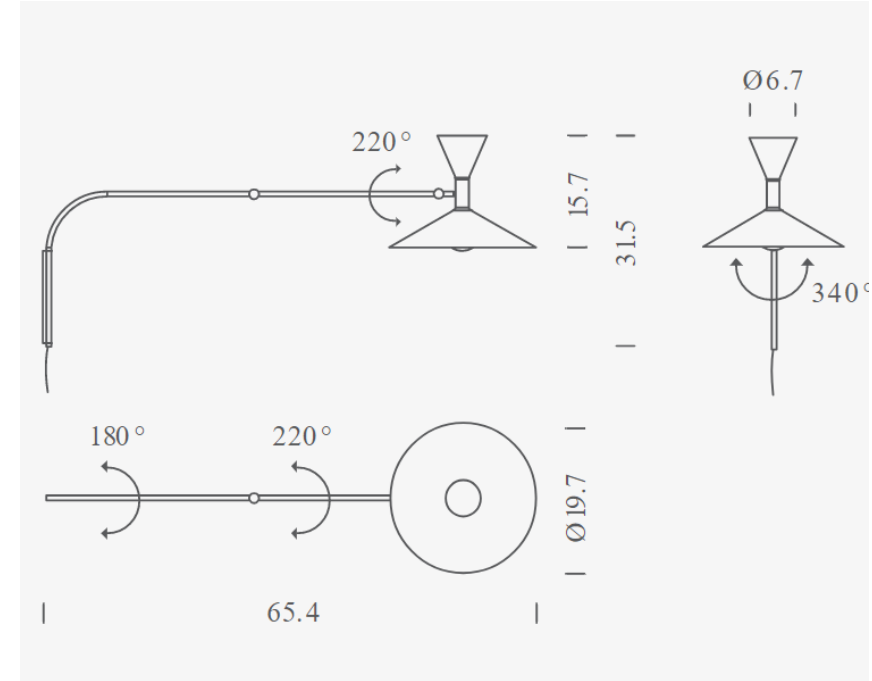
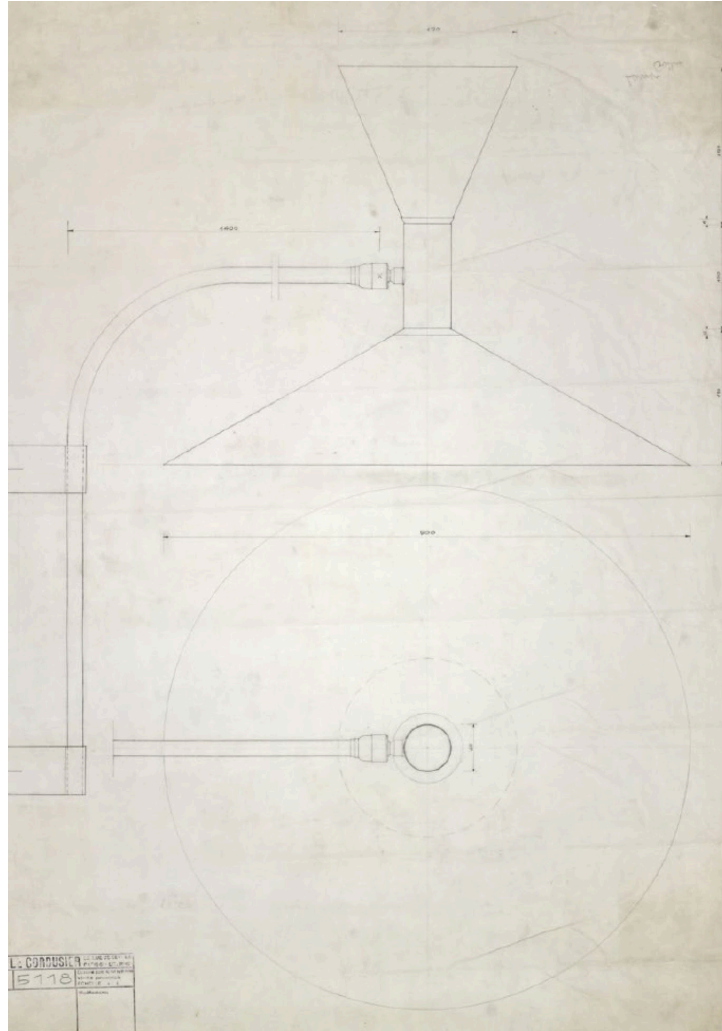

● whitewash

○ grey

● black

- Two dimensions:
- Standard and mini





















LAMPE DE MARSEILLE MINI

LE CORBUSIER

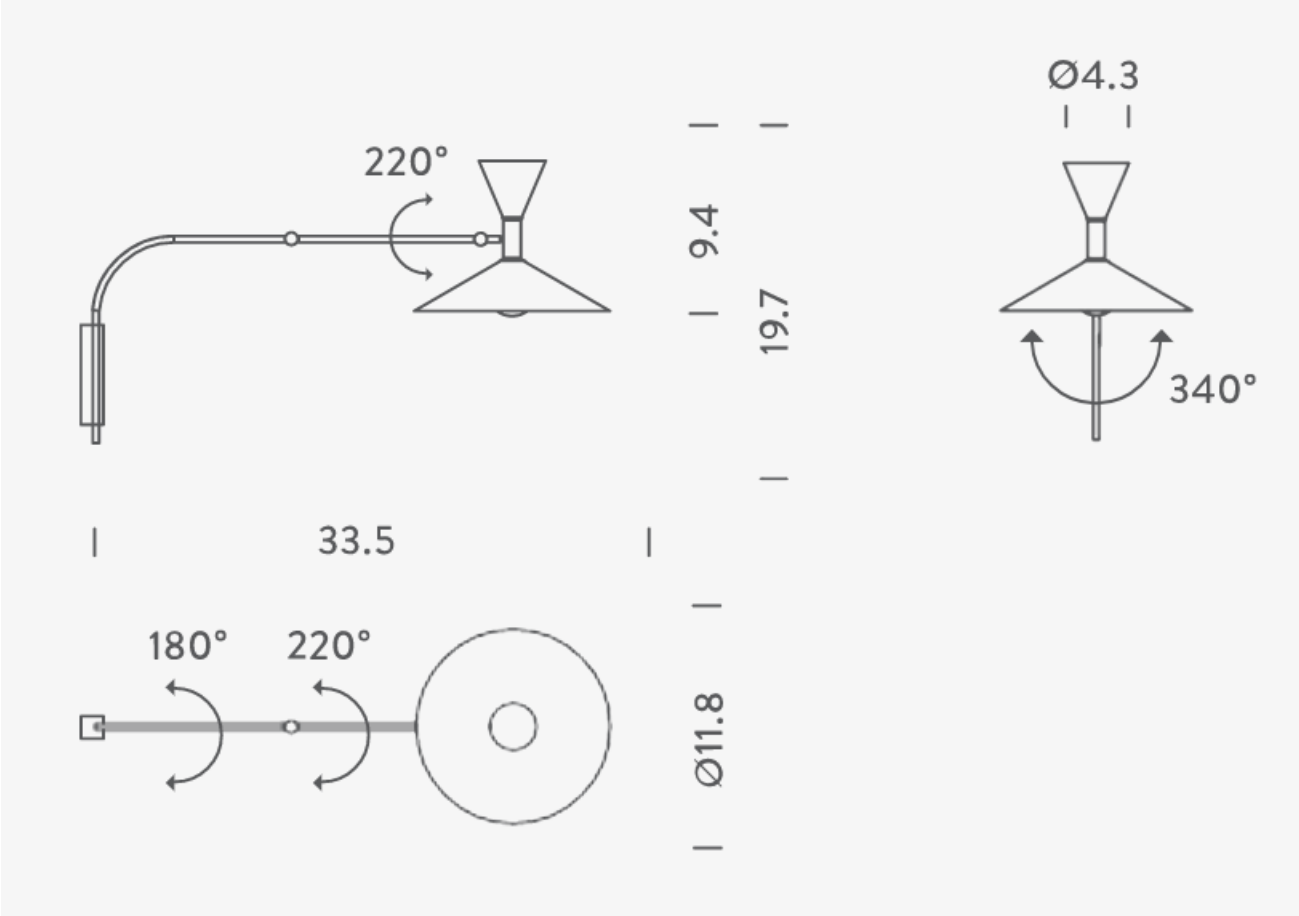

plug and play – can be hardwired





APPLIQUE DE MARSEILLE

LE CORBUSIER 1938-1939

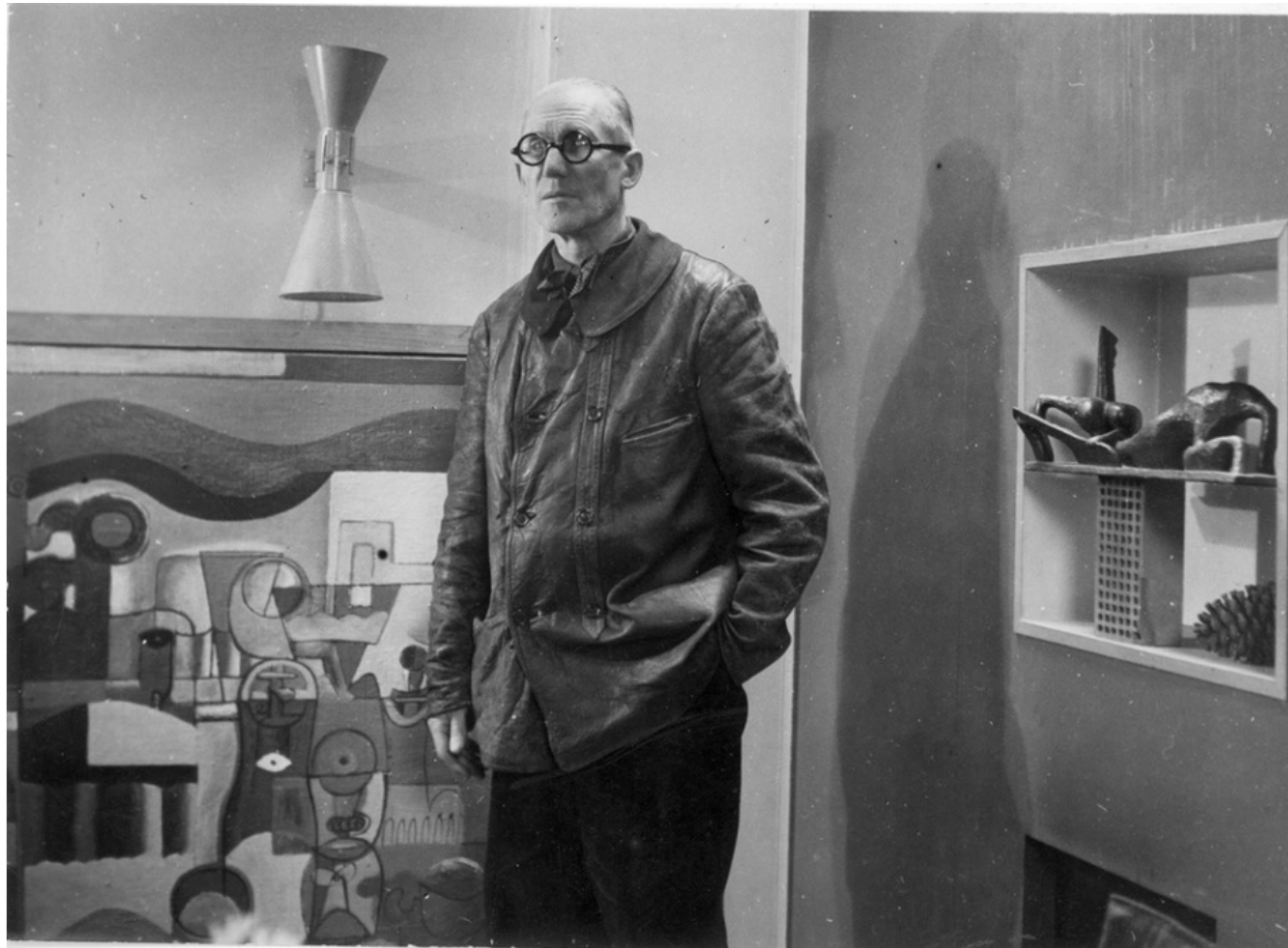

○ whitewash

○ grey

● black

- Two dimensions:
- Standard and mini

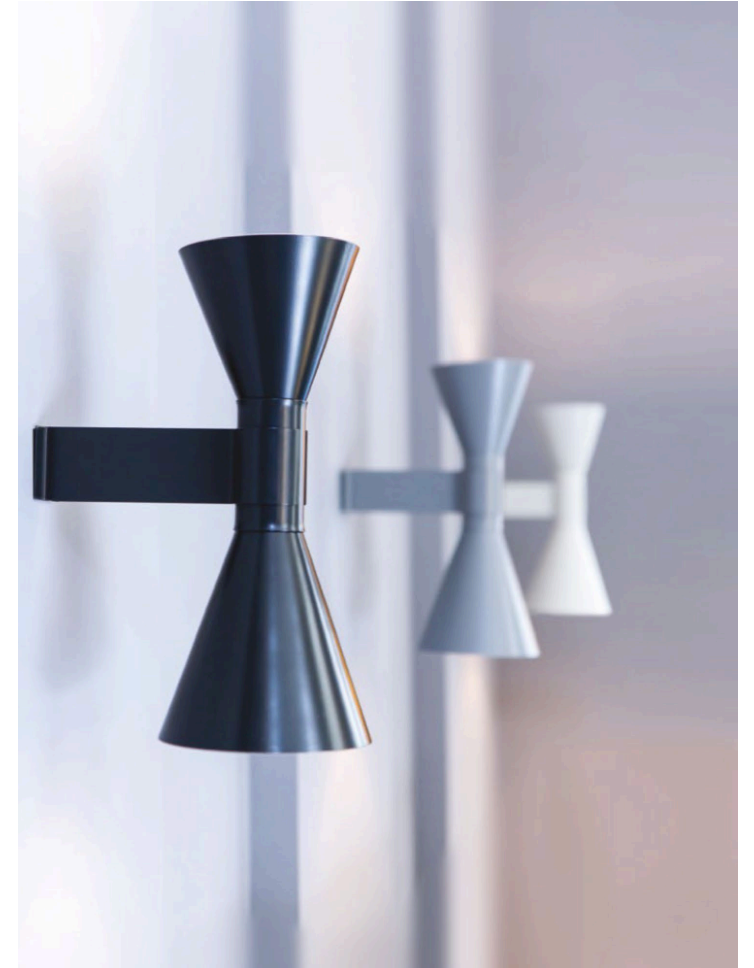

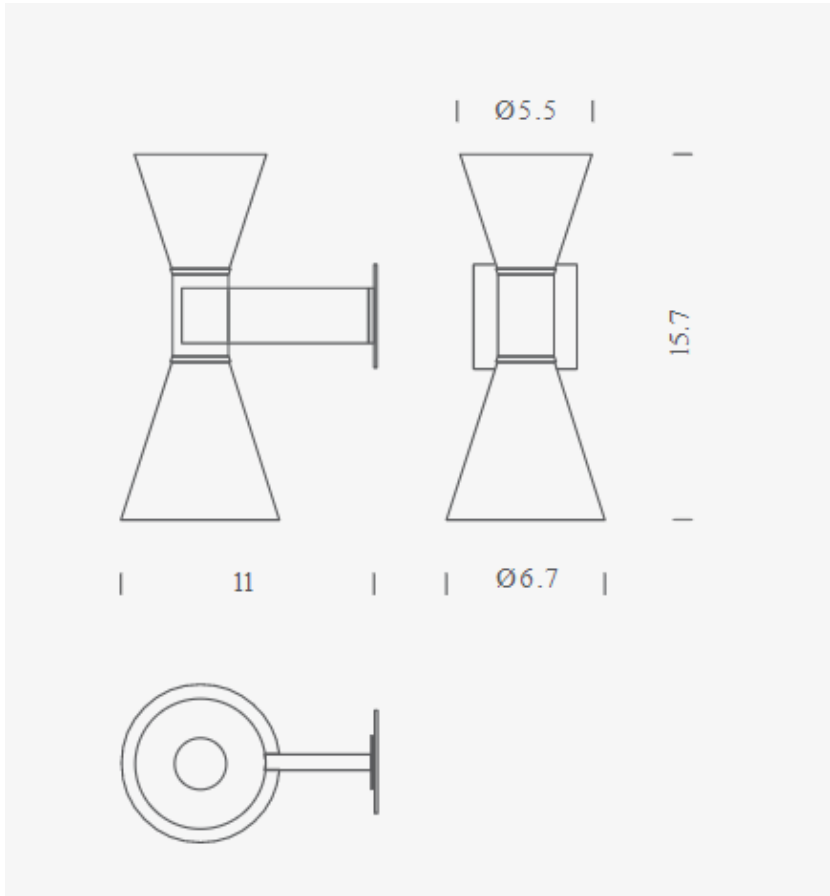









APPLIQUE DE MARSEILLE MINI

○ whitewash

● grey

● black

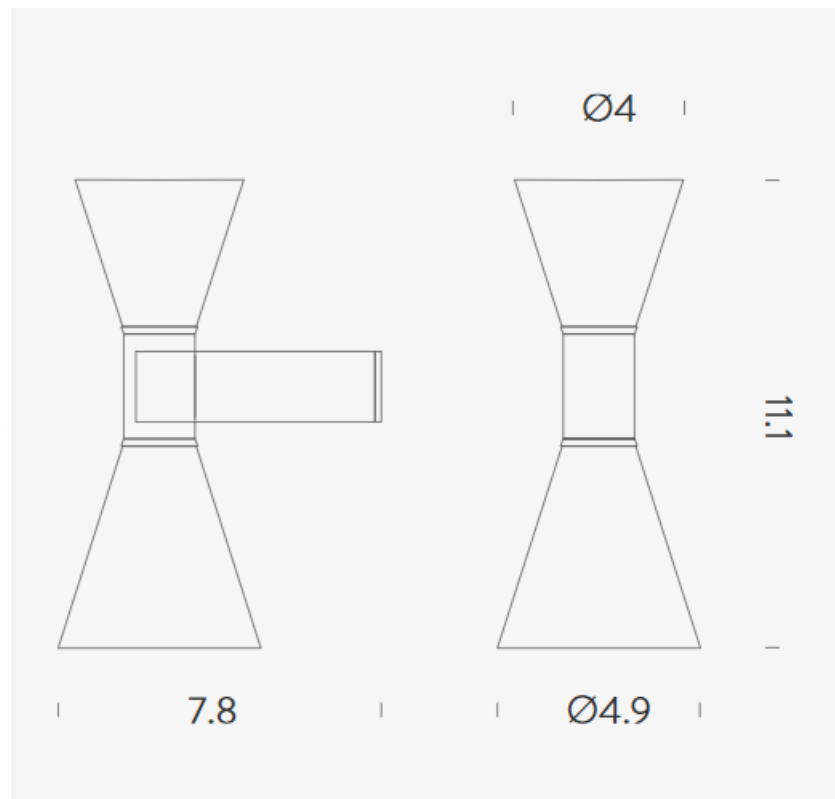

PROJECTEUR 365 | 165

LE CORBUSIER 1954

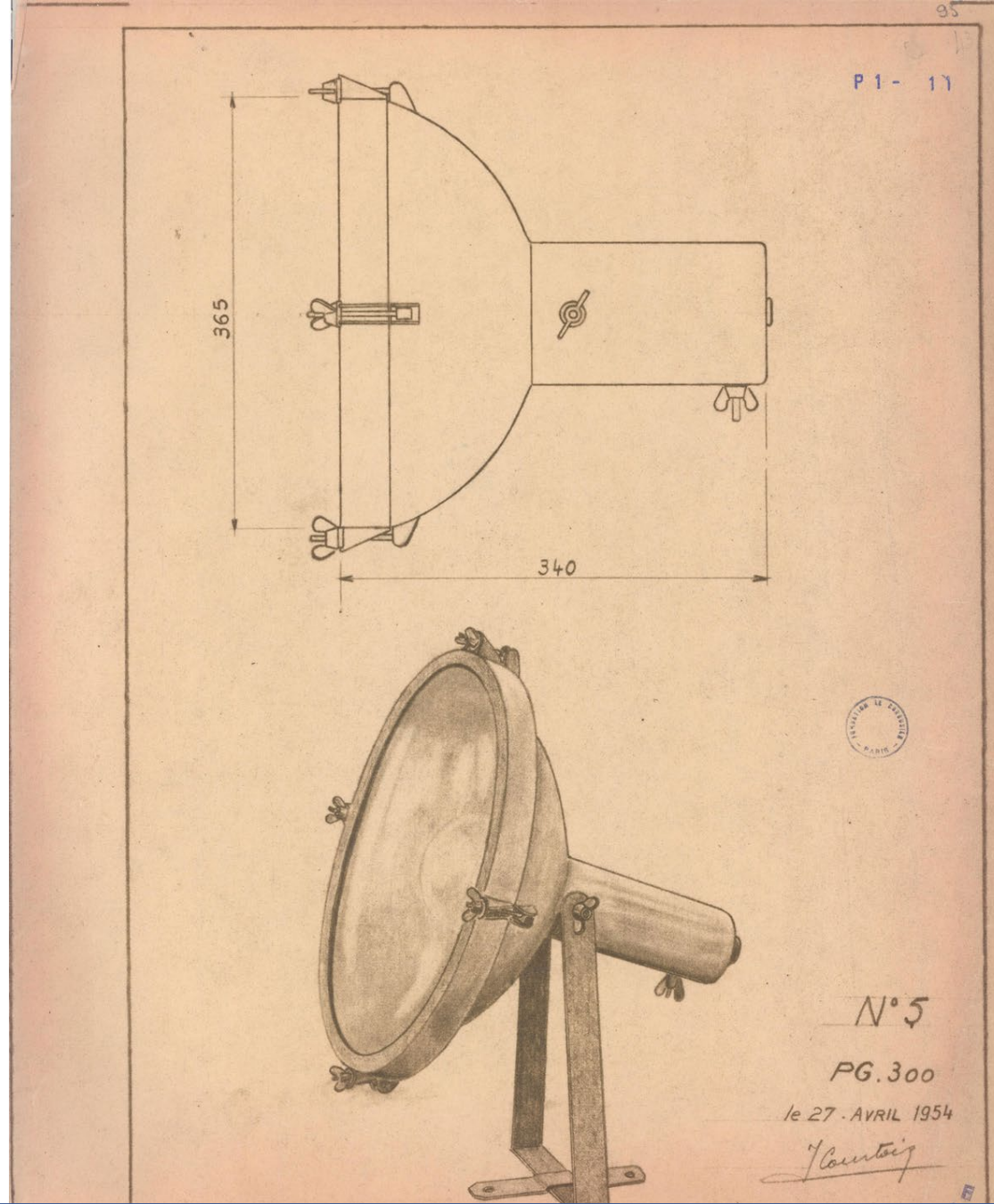



PROJECTEUR 365



PROJECTEUR 165



● night blue

● white sand

● moka

- Two dimensions:
- Standard and mini
- Outdoor (wet rated) or indoor
- Floor, pendant, table, wall/ceiling, pin with clip























CHANDIGARH



PARLIAMENT

LE CORBUSIER 1963

○ grey/whitewash

● green/yellow

● black/yellow

● black/red

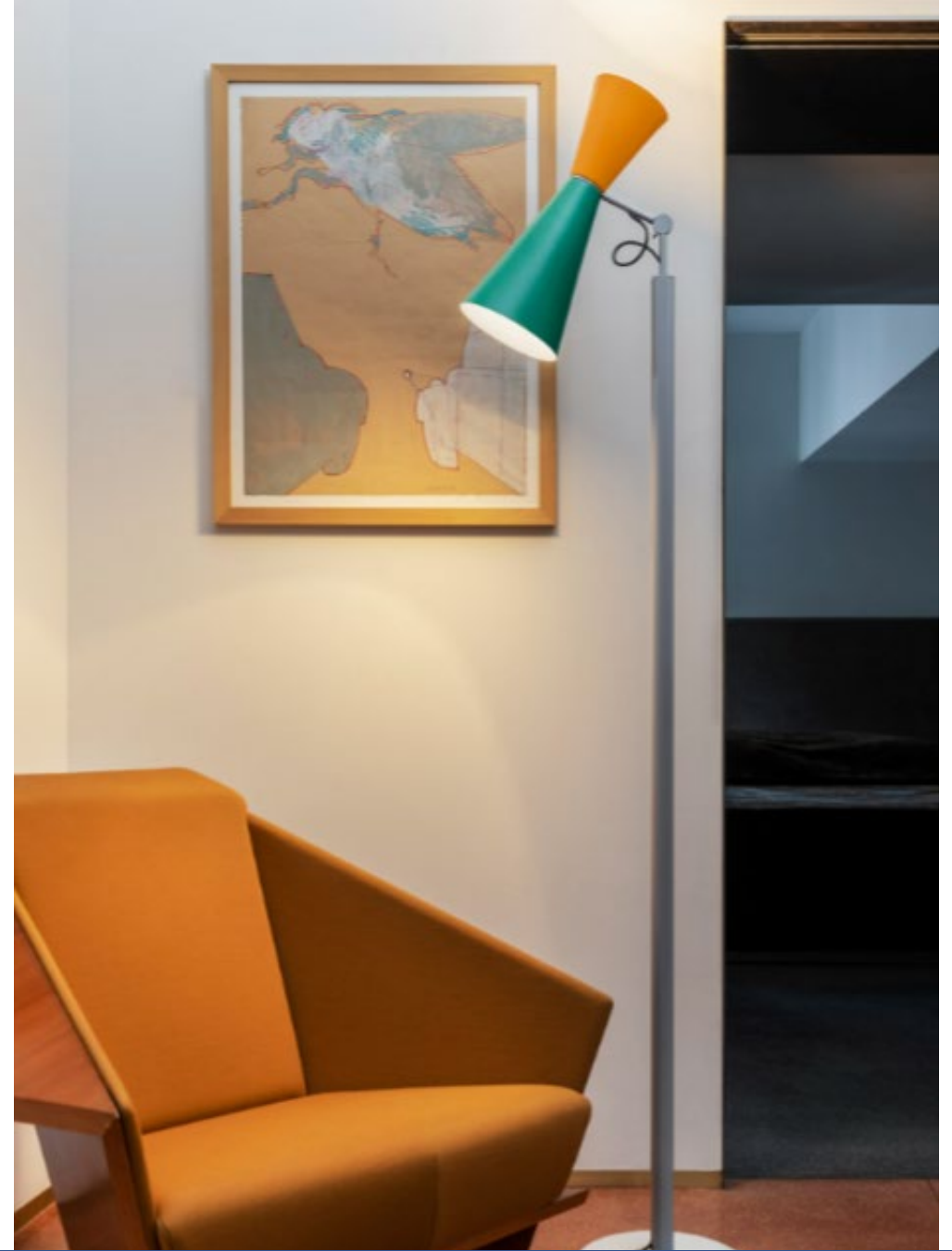





LA ROCHE

LE CORBUSIER 1925

● grey

● black







Vico Magistretti

“The most important thing for me is conceptual simplicity, which is usually translated into constructive clarity. A conceptually simple object could be made just using the telephone”.



CLARITAS

Vico Magistretti 1946

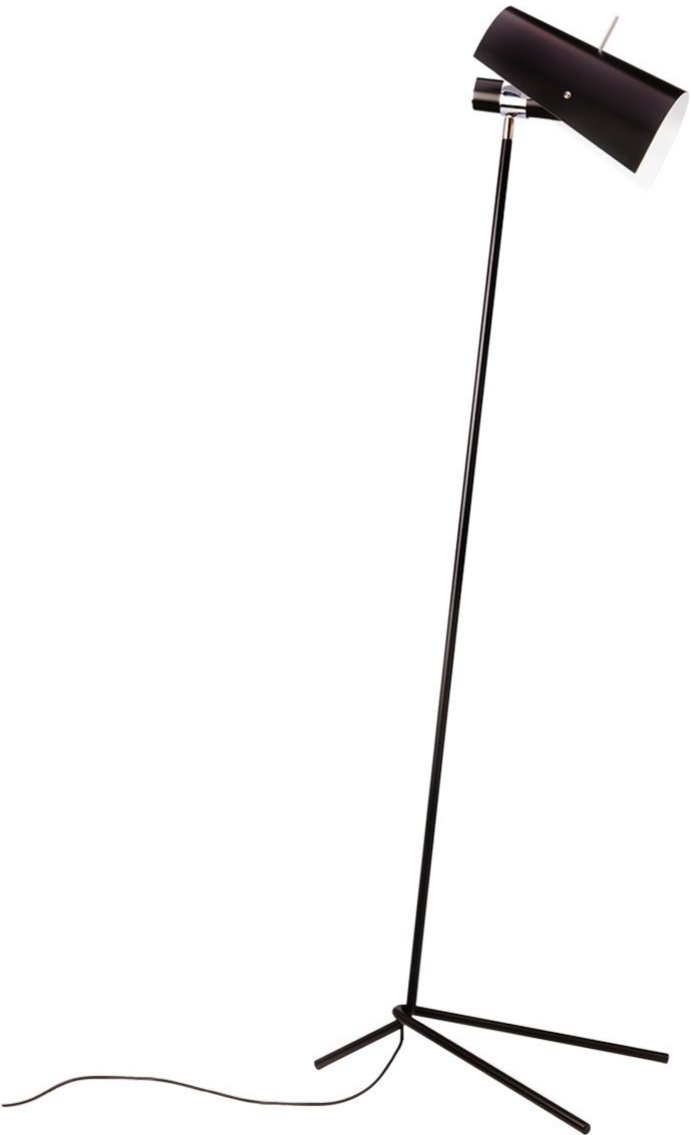



Charlotte Perriand:
The Modern Life

Opens 19 June

the
**DESIGN
MUSEUM**



LAMPE DE BUREAU

Charlotte Perriand 1965



● green

● yellow

● red

● blue mare

● blue grey

○ white

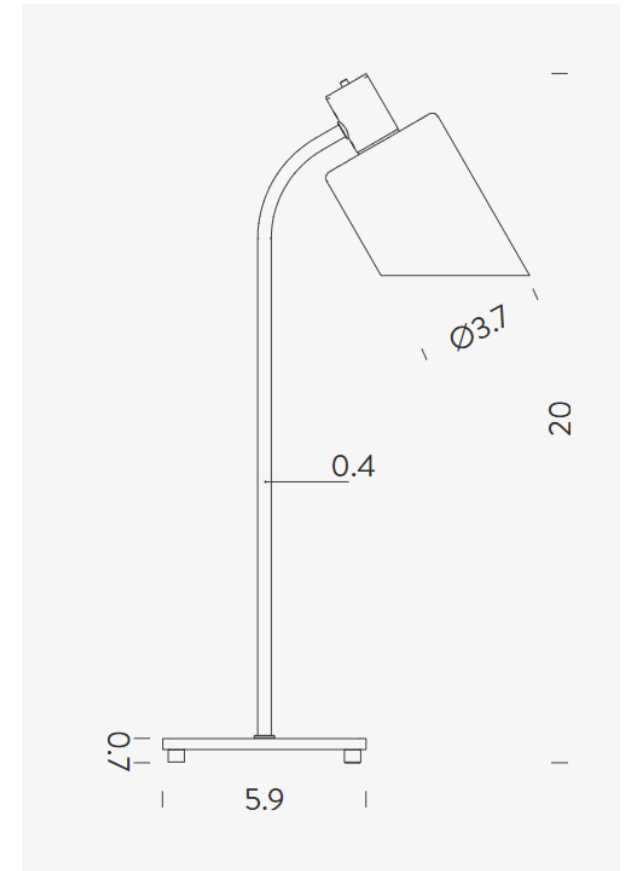

- Reading / Wall / Table

- Reading / wall / table

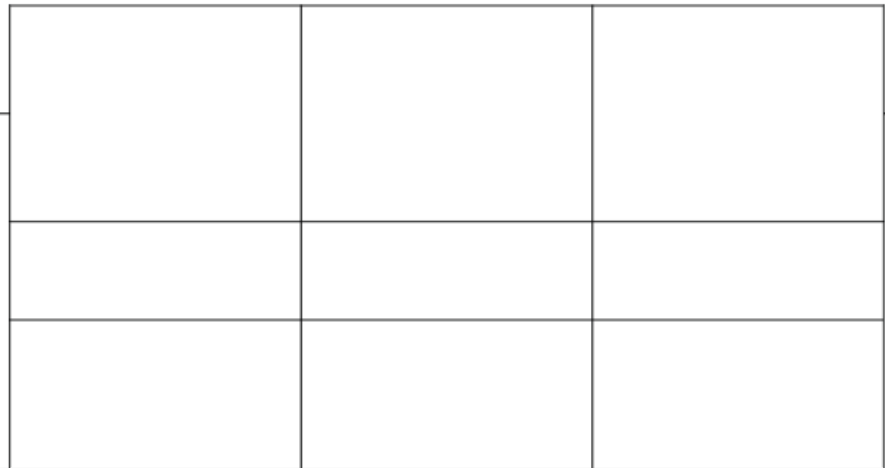
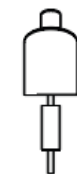
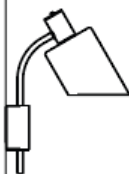



LAMPE DE BUREAU APPLIQUE

Charlotte Perriand 1965



Applique Cylindrique

Charlotte Perriand 1930



● pastel blue

● anthracite grey

○ whitewash



- Two dimensions:
- Petite and longue







PIVOTANTE À POSER

CH.PERRIAND 1950

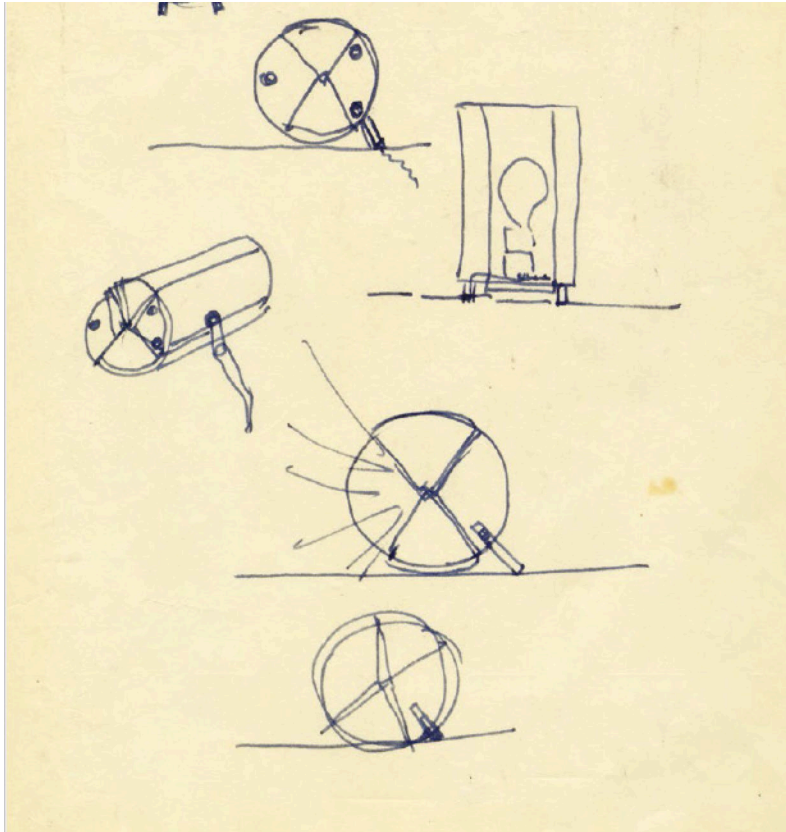

○ white

● yellow

● blue

● pastel blue

● carmine red

● sage green

● light grey



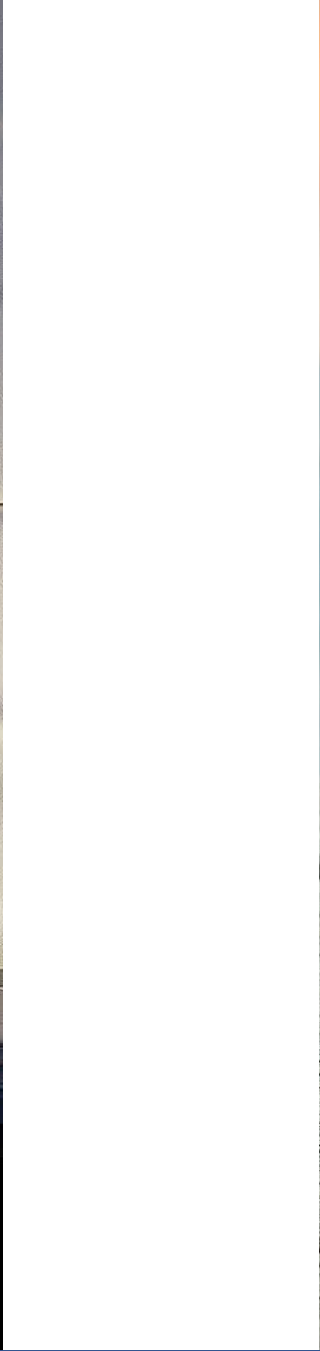

APPLIQUE À VOLET PIVOTANT

Charlotte Perriand 1960-1988



APPLIQUE À VOLET PIVOTANT

SINGLE



● black anodized

● natural anodized

○ white

● red

● yellow

● blue

● polished inox

LED board

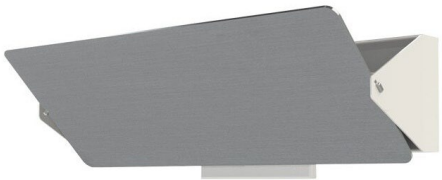

APPLIQUE À VOLET PIVOTANT

DOUBLE



APPLIQUE À VOLET PIVOTANT

PLIE

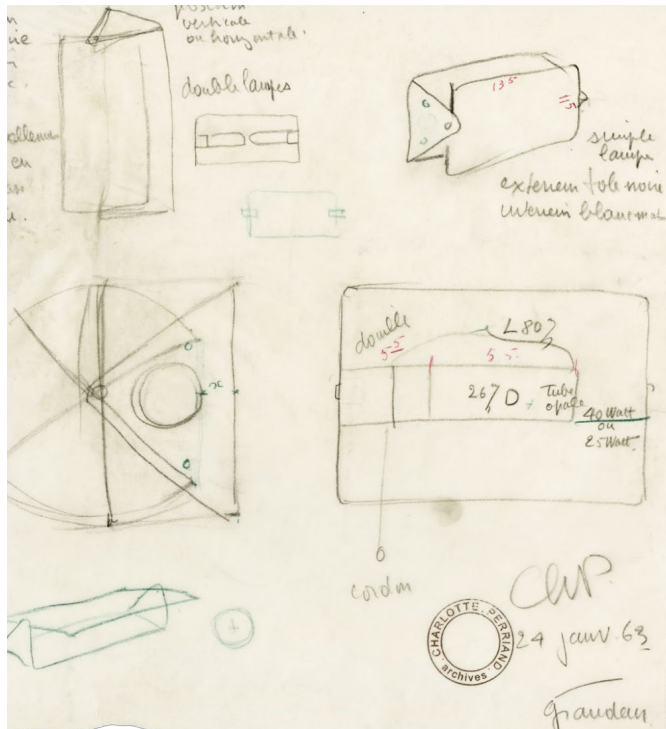









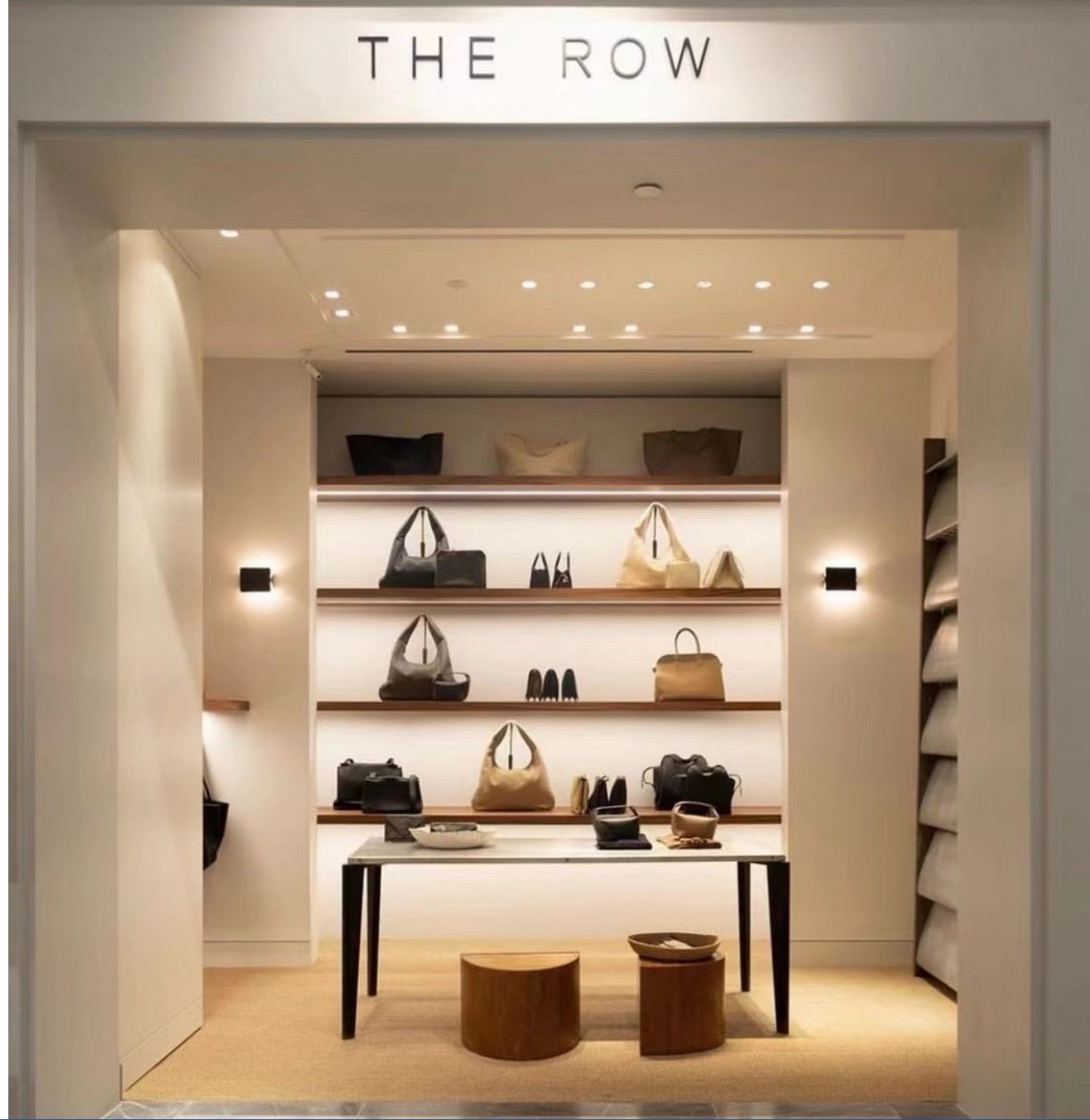





POTENCE PIVOTANTE

Charlotte Perriand 1938



- black
- red
- grey







POTENCE PIVOTANTE MINI

Charlotte Perriand 1938



- Two dimensions:
- Standard and mini

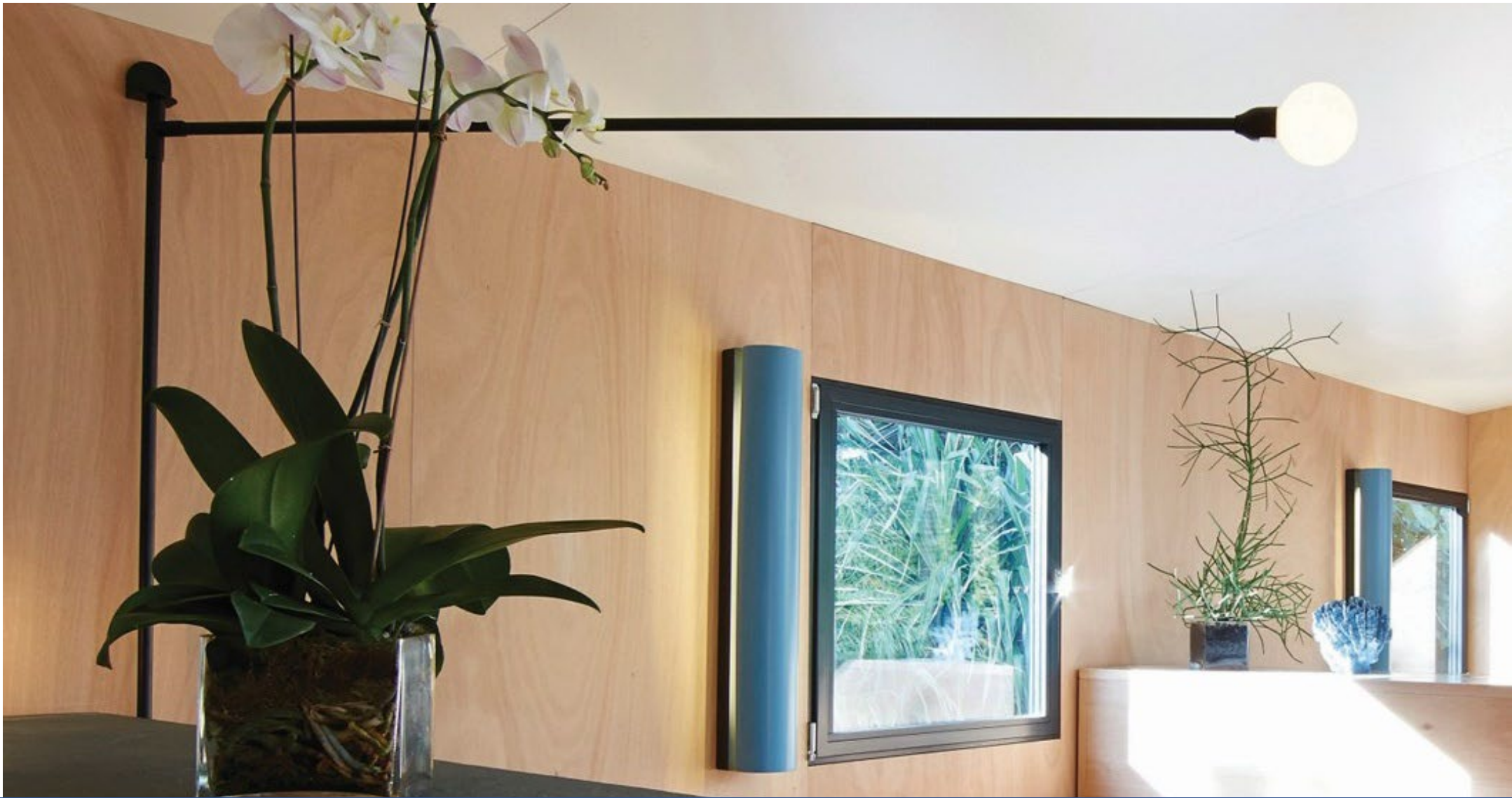





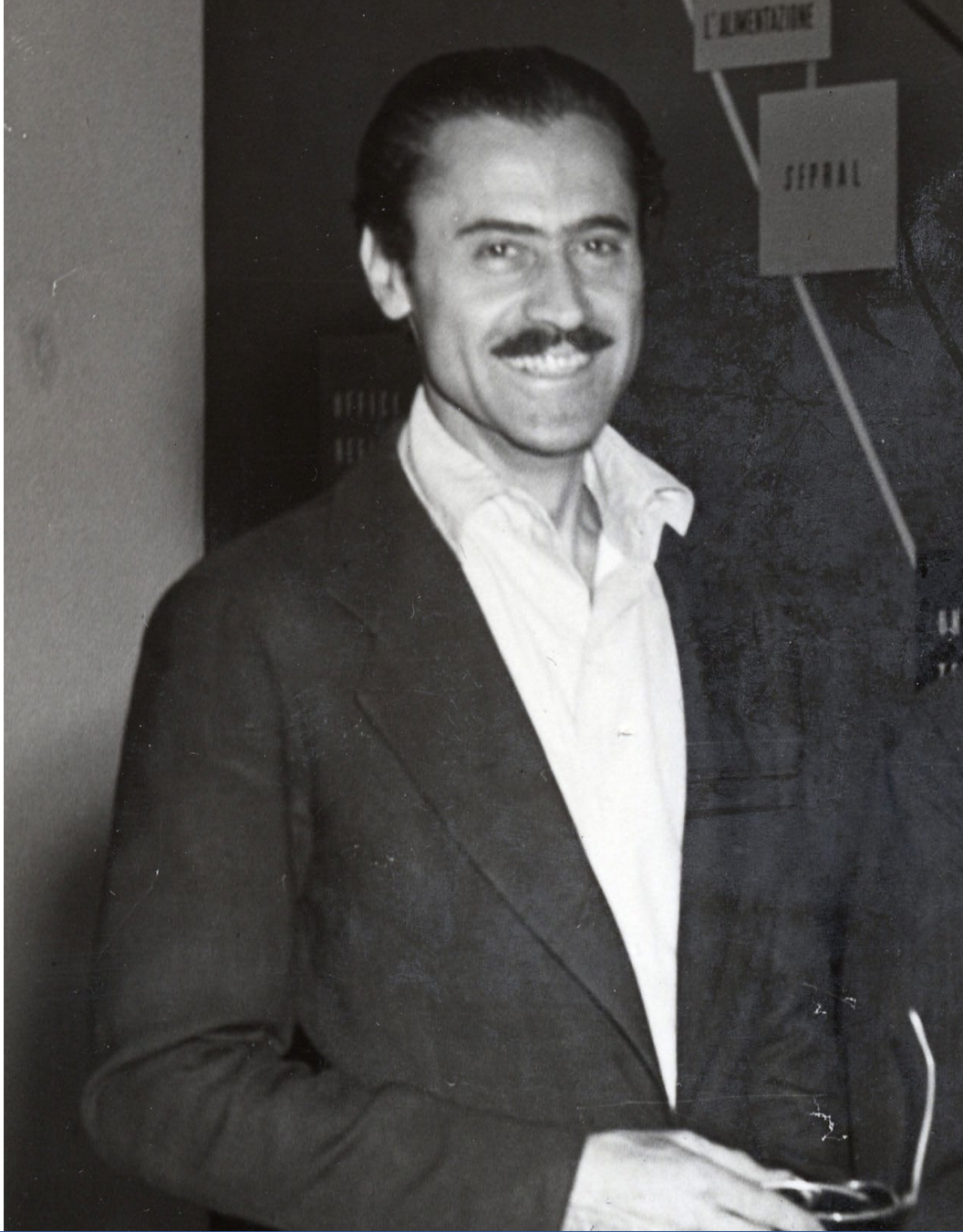

Franco Albini

“To us, the educational value resides in our works, and it’s through them that we spread ideas more than through ourselves”.

COLLEZIONE ALBINI

Franco Albini 1969

● black/white glass

○ chrome/white glass



- Ceiling, wall, floor, table
- Hand blown triplex opal diffuser or chrome diffuser.
- 10 variants



- 2 Table: only glass
- 1 Table: only glass
- 3 Ceiling: only glass
- 2 Floor: chrome and glass
- 2 Suspension: chrome and glass
- Triple diffuser
- Adjustable arm

NEMO



ALBINI FAMILY - 1969

From a modular system
to an industrial production















CEILING WALL U.S. COLLECTION

JANEIRO - flushmount



| 8.5-10-12-14.5-16.5-18.5 |



4.2-4.3-4.3-5.1-5.1-5.1



SOLEIL - flushmount

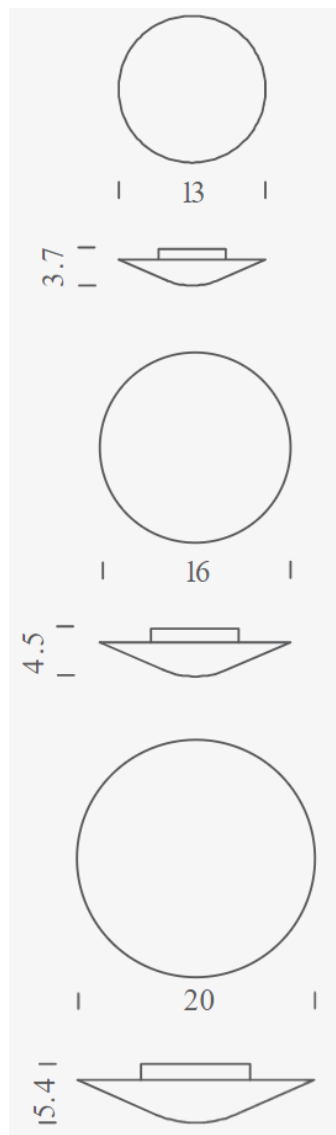

SPOTLIGHTS

SPOTLIGHTS



Elba

- CCT: 2700K/ 3000K
- **CRI>90**
- 13W
- Flux: 900lm
- Optic Zoom: da 15° a 55°
- Integrated driver
- Triac
- Finishes: black, white
- Dimensions : Ø5,6x15cm

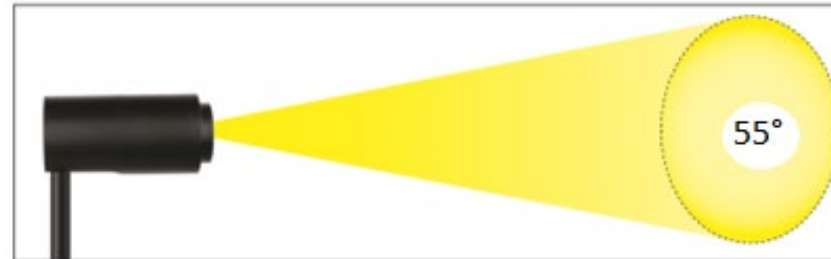

Capri

- CCT: 2700K/ 3000K
- **CRI>90**
- 28W
- Flux: 1500lm
- Optic Zoom: da 15° a 55°
- Integrated driver
- Triac or 1-10V o DALI
- Finishes: black, white
- Dimensions : Ø7,3x17cm

SPOTLIGHTS



precise light distribution



integrated driver

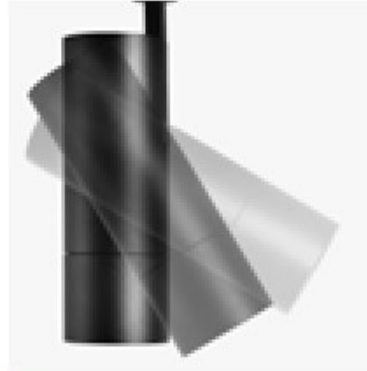

90° rotation



Anti glare system



matt black finishing



adjustable beam 15°-55°



Private House - Tokyo

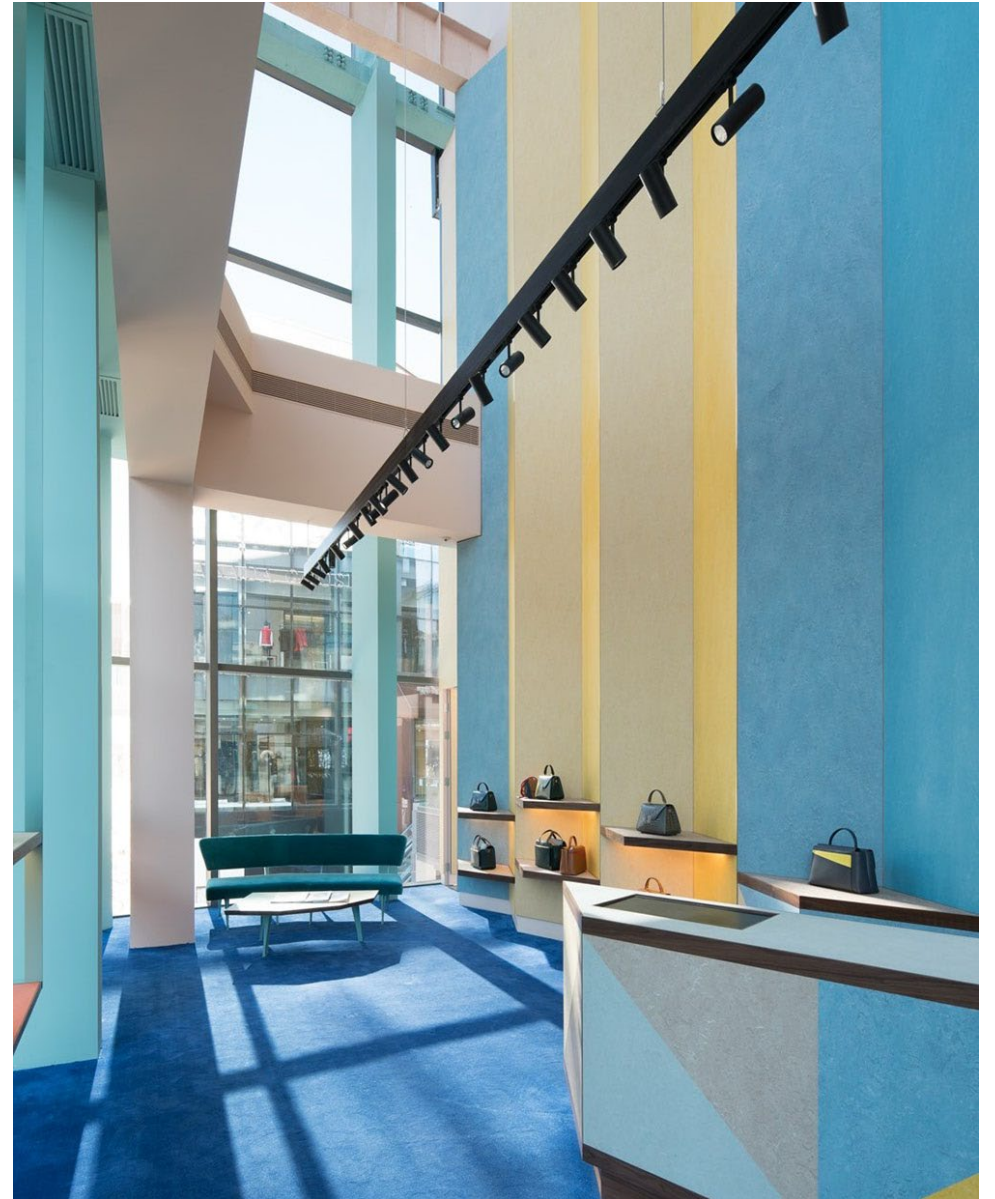

Valextra - Beijing



Molteni & C



Poliform

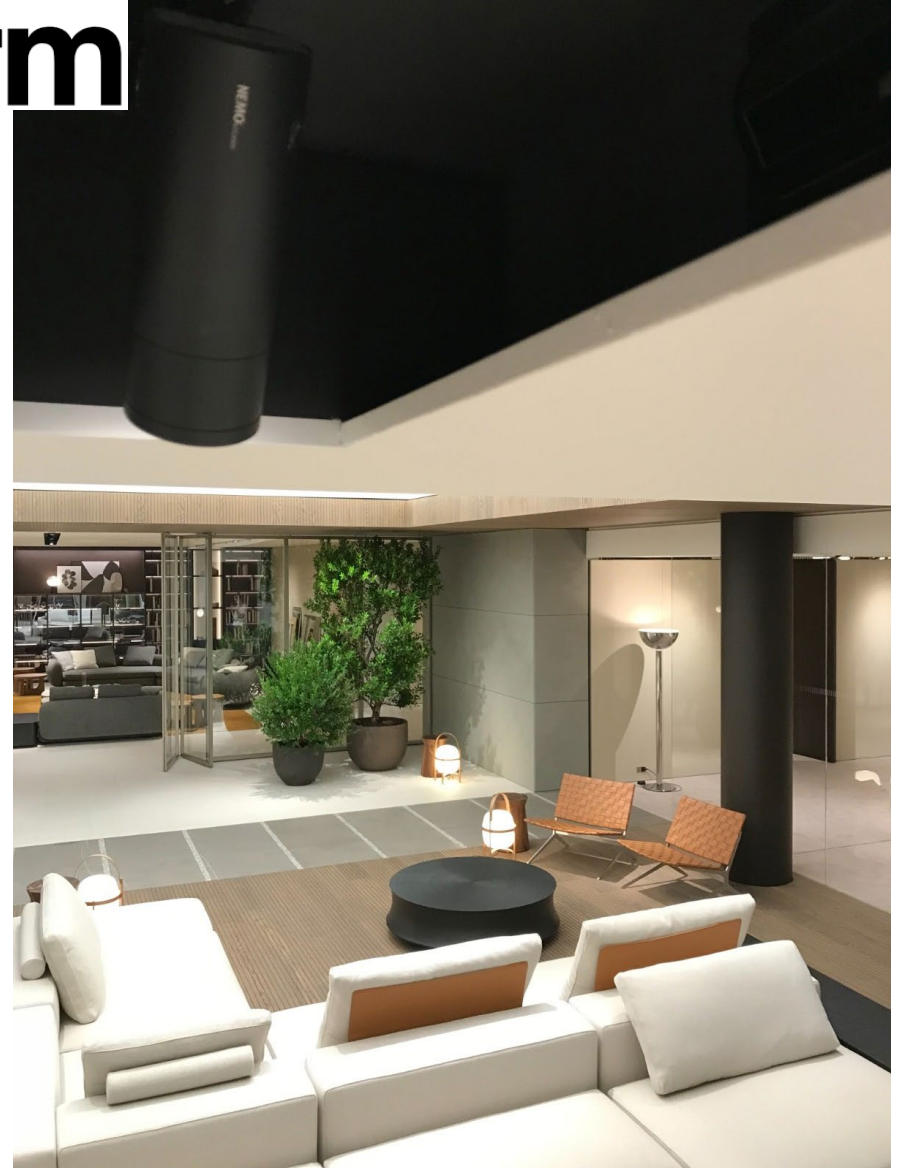



Minotti







ELBA

Options:

1. Honey comb
2. Oval Glass
3. Sanded Glass



FIND US ONLINE



[INSTAGRAM](#)



[FACEBOOK](#)



[PINTEREST](#)



[LINKEDIN](#)



[TWITTER](#)



[WECHAT](#)

NEWSLETTER
[STAY CONNECTED](#)

NEMO

nemolighting.com

NEMO FRANCE

nemolighting.com/fra/

NEMO USA

nemolighting.com/us

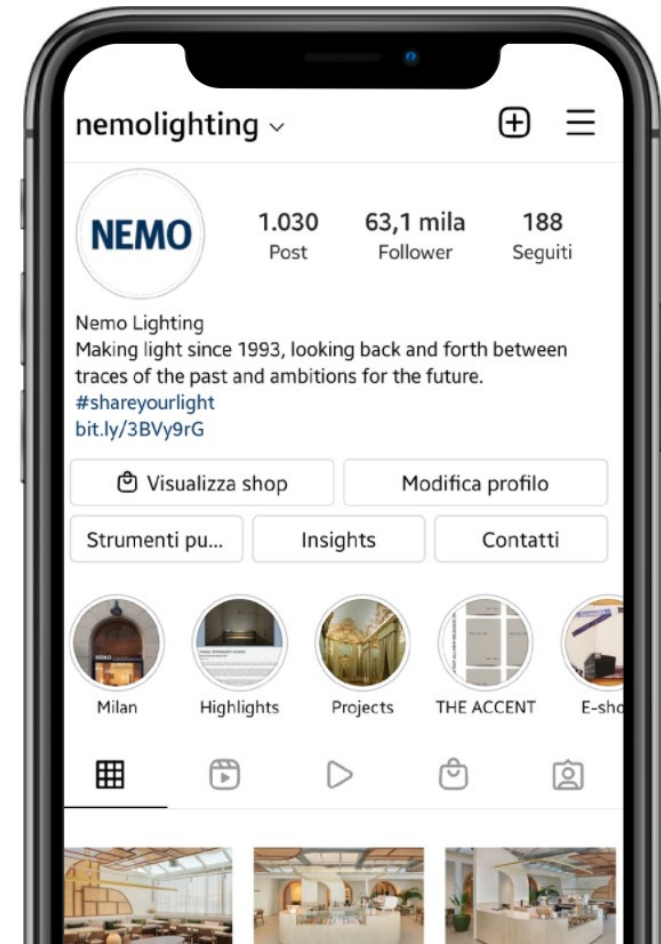

CONTACTS

Pietro Gennaro– General Manager

 pietro.gennaro@nemolighting.com

 +1 908 417 9888

SOCIAL

 INSTAGRAM

 FACEBOOK

 TWITTER

 YOUTUBE

 LINKEDIN