

Glamour, Modern *Seduction.*

design Dodo Arslan
terzani.com



| | | |
|-----------|---|-------------|
| Type | | Table lamp |
| Materials | | Metal |
| Finishes | | Code |
| White |  | 0N15B E8 C8 |
| Nickel |  | 0N15B E7 C8 |
| Gold |  | 0N15B H8 C8 |

Light Source |



Glamour's randomly interspersed rings imbue this design with a seductiveness rarely applied to geometric shapes. Whether finished in gold, nickel or white, the diffused light emanating behind Glamour's rings bathes the surrounding area in a soft, sensuous glow. Available as a wall sconce, table lamp or pendant, glamour can provide subtle accents or act as the focal point of a room. Design Dodo Arslan.

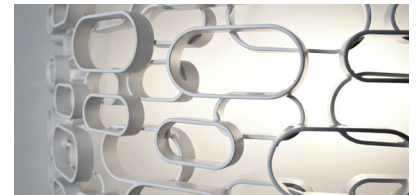

Body |

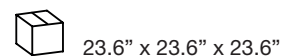
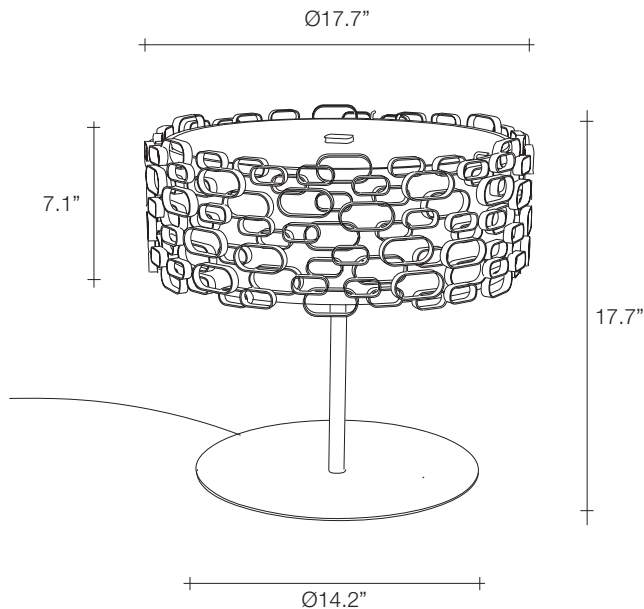

Glamour, Modern *Seduction.*

design Dodo Arslan
terzani.com



| | | |
|------------------|--|-------------|
| Type | | Suspension |
| Materials | | Metal |
| Finishes | | Code |
| White | | 0N16S E8 C8 |
| Nickel | | 0N16S E7 C8 |
| Gold | | 0N16S H8 C8 |

Glamour's randomly interspersed rings imbue this design with a seductiveness rarely applied to geometric shapes. Whether finished in gold, nickel or white, the diffused light emanating behind Glamour's rings bathes the surrounding area in a soft, sensuous glow. Available as a wall sconce, table lamp or pendant, glamour can provide subtle accents or act as the focal point of a room. Design Dodo Arslan.

Light Source |

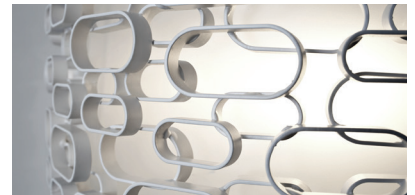
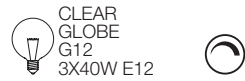

Body |

Canopy |

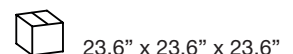
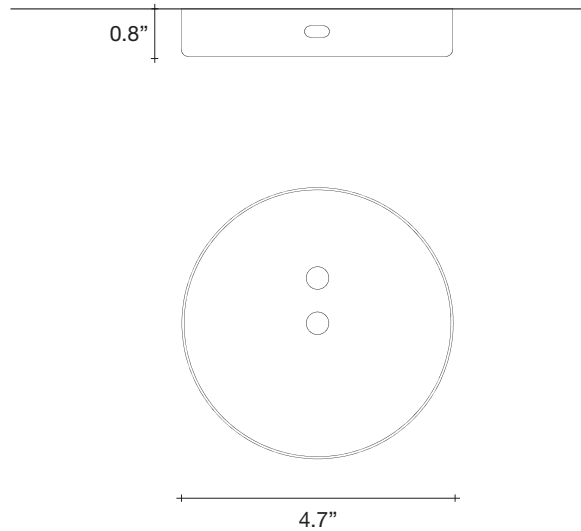
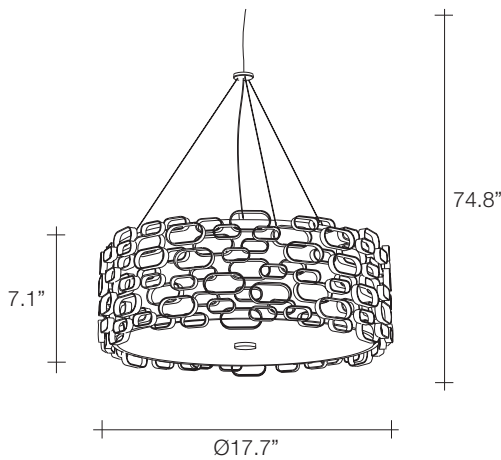

Glamour, Modern *Seduction.*

design Dodo Arslan
terzani.com



Type | Wall Sconce

Materials | Metal

Finishes | Code

White  0N18A E8 C8

Nickel  0N18A E7 C8

Gold  0N18A H8 C8

Light Source |



Glamour's randomly interspersed rings imbue this design with a seductiveness rarely applied to geometric shapes. Whether finished in gold, nickel or white, the diffused light emanating behind Glamour's rings bathes the surrounding area in a soft, sensuous glow. Available as a wall sconce, table lamp or pendant, glamour can provide subtle accents or act as the focal point of a room. Design Dodo Arslan.

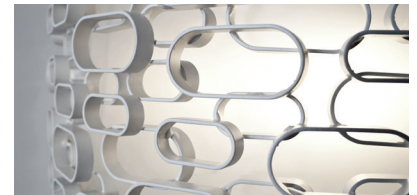

Body |

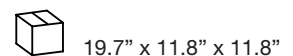
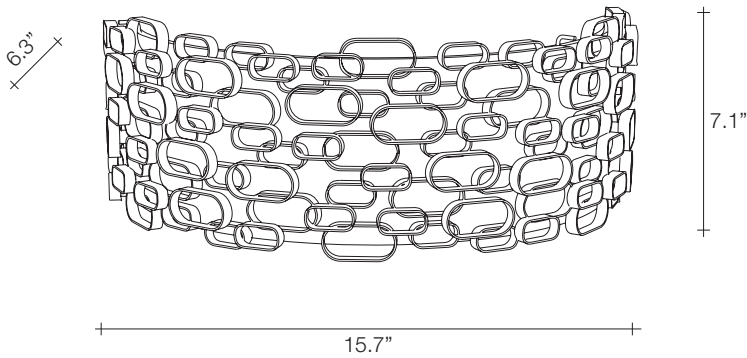



Glamour, Modern *Seduction.*

design Dodo Arslan
terzani.com



Type | Ceiling Lamp
Materials | Metal

Finishes | **Code**

| | | |
|--------|---|-------------|
| White |  | 0N17L E8 C8 |
| Nickel |  | 0N17L E7 C8 |
| Gold |  | 0N17L H8 C8 |

Light Source |

 CLEAR GLOBE G12 3X40W E12



Glamour's randomly interspersed rings imbue this design with a seductiveness rarely applied to geometric shapes. Whether finished in gold, nickel or white, the diffused light emanating behind Glamour's rings bathes the surrounding area in a soft, sensuous glow. Available as a wall sconce, table lamp or pendant, glamour can provide subtle accents or act as the focal point of a room. Design Dodo Arslan.



Body |

Canopy |

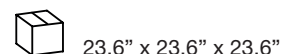
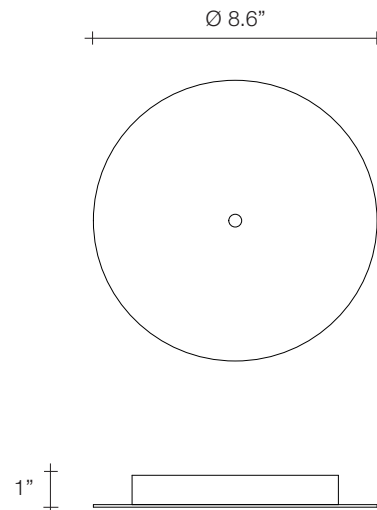
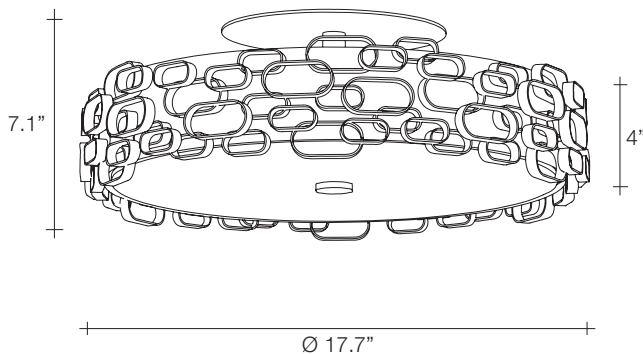

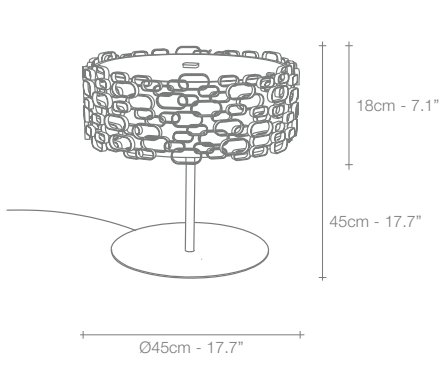

N15B

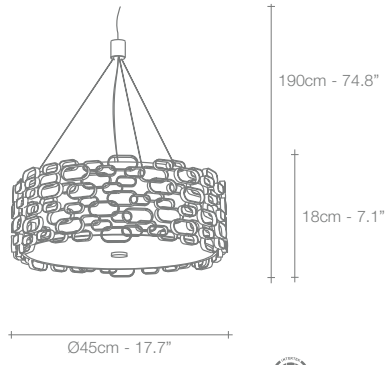

N16S

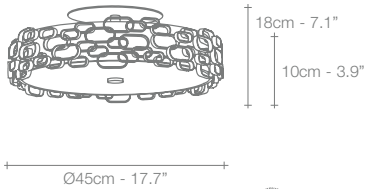

N17L



16cm - 6.3"

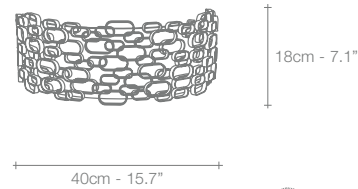

N18A



WHITE



NICKEL



GOLD

| | | | | | | |
|-------------|---|------------------------|-------------------|-------------------|---|---|
| |  | N15B | N16S | N17L |  | N18A |
| 230V | HALOGEN ES E14 | 3X28W (=3X40W) | 3X28W (=3X40W) | 3X28W (=3X40W) | HALOGEN ES R7S | 48W (=60W) |
| 120V |  | CLEAR GLOBE G12 E12 | 3X40W | 3X40W | 3X40W |  HALOGEN J-SHORT R7S 75W |