

TINTO MEDIUM PENDANT

Installation Guide

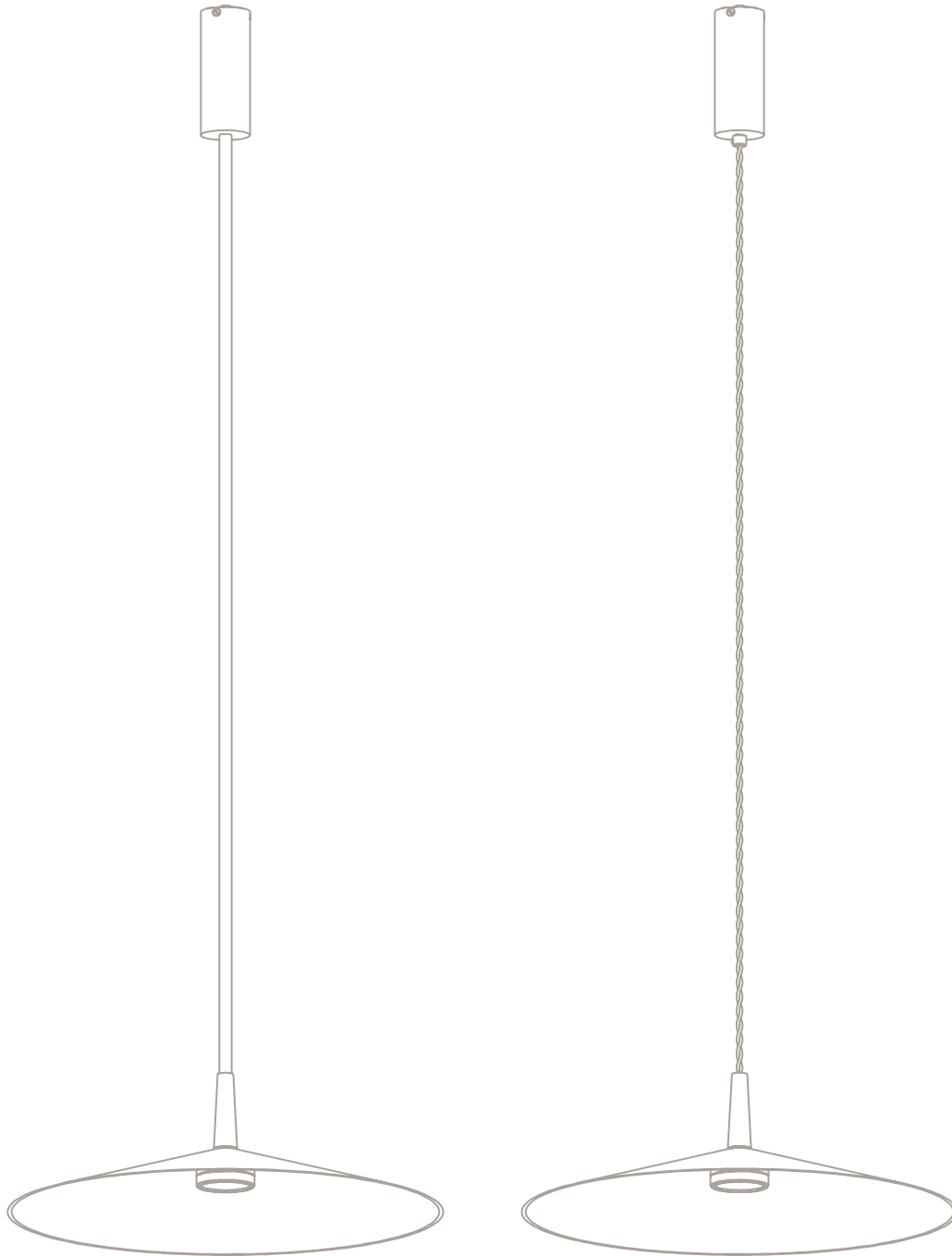

!

Please handle with care and wear gloves at all times during assembly and installation to avoid damaging components.

TECHNICAL

Bulb Holder
integrated LED
trailing edge dimmable

Wattage
8w - 2700k

Weight
7kg (15.4lbs)

PARTS & COMPONENTS

- A. Mounting plate
- B. Ceiling rose with drop rod and LED module with cable (drop rod version) or
- C. Ceiling rose with LED module and silk braided cable (cable version)
- D. Metal shade
- E. Threaded cone
- F. LED driver

A.



B.

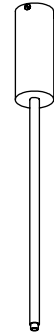

C.



D.

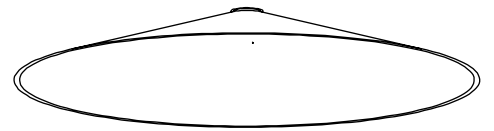

E.



F.

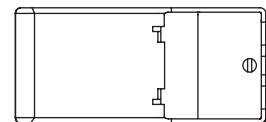

- All nuts and bolts required for assembling the light are included.



BEFORE INSTALLATION

- Check that you have all components before starting the installation.
 - Installation must be carried out by a qualified electrician.
 - A minimum of two people is required to install a pendant light.
- Check that the ceiling or wall fixings are suitable and strong enough to support the weight of the light fixture.
 - You will need these specific tools for a successful installation.

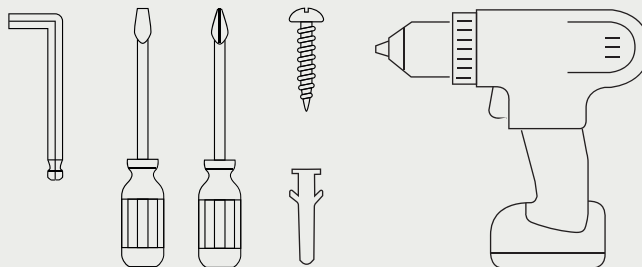

HEIGHT ADJUSTMENT INSTRUCTIONS (DROP ROD CONFIGURATION)

Before attaching the drop-rod to the body of the light, calculate the required total drop from ceiling to bottom of pendant. If any height adjustment is required, follow the steps below:

1. Separate the brass tube and the internal threaded tube from the ceiling rose cover by unscrewing the internal threaded tube.

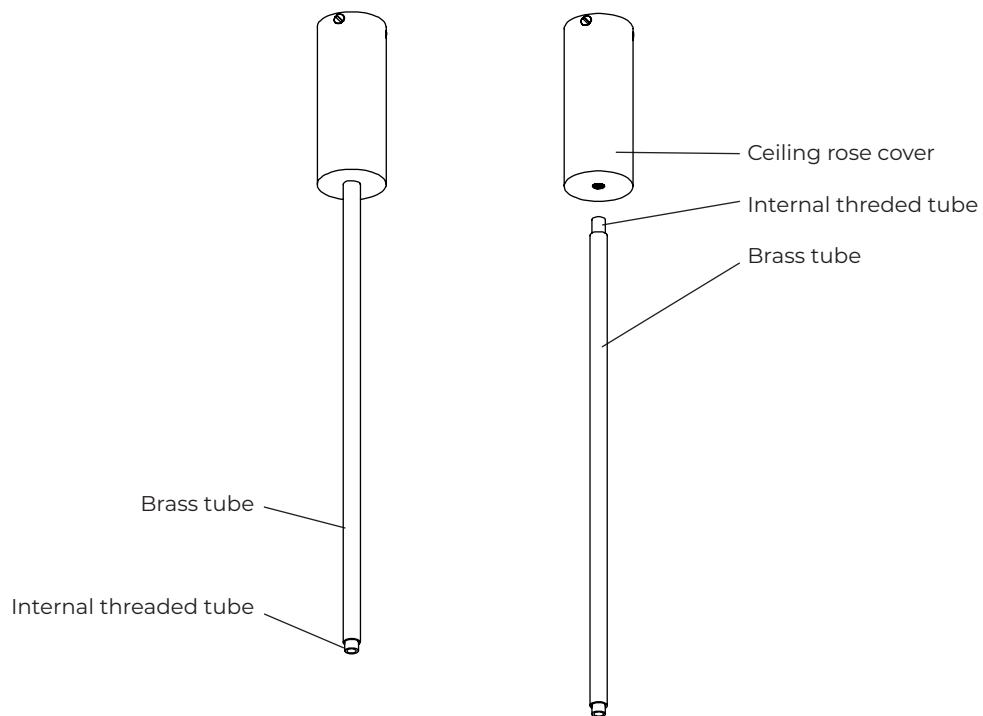

2. Measure the length the drop rod needs to be.
3. Cut the brass tube to this length using a hacksaw or similar tool.
4. Cut the same length from the internal thread tube.

NOTE: The internal threaded tube must always be longer than the brass tube.

5. Once the brass tube and internal threaded tube are cut to correct lengths, screwing the internal threaded tube to the ceiling rose cover and slide the brass tube over the it.

1.
 - A. Feed the power cable from the LED module, through the metal shade and threaded cone.
Screw the threaded cone to the LED module
 - B. Feed the power cable from the drop rod into the ceiling rose cover.
Screw the drop rod to the central hub of the pendant.

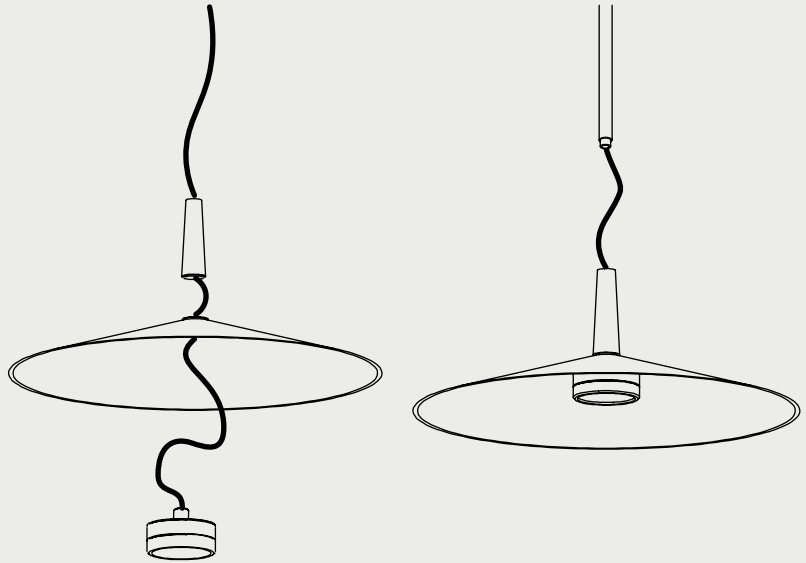

1. for cable suspension
 - A. Feed the power cable from the LED module, through the metal shade and threaded cone.
Screw the threaded cone to the LED module
 - B. Feed the power cable from into the ceiling rose cover.
Secure the cable into position by screw the nylon screw below the ceiling rose cover.

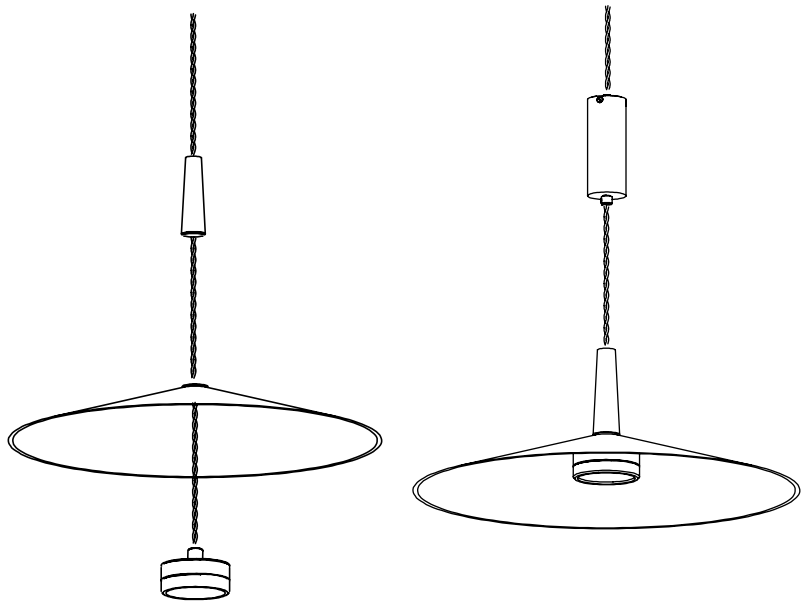

2. Make power connection to the LED driver. See wiring diagram below.
Dimmer is optional. Please note, use trailing edge dimmer switch only.
- Note: + is the red cable going to LED module
- is the black cable going to the LED module

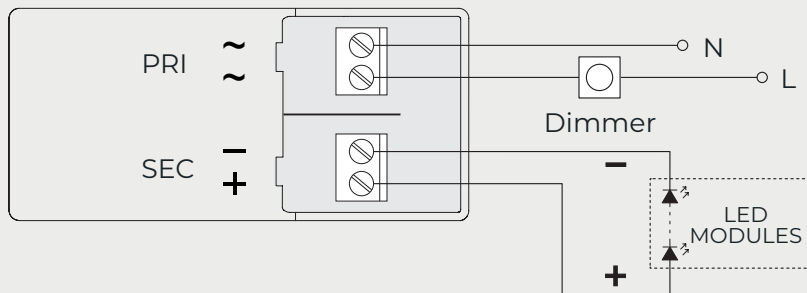

- 3.** Fix the mounting plate to the ceiling. Ensure that suitable screws are being used for the surface that you are mounting to (not supplied).

Raise the pendant and make the electrical connections ensuring all wires are colour matched and the pendant is earthed correctly.

Bring the ceiling rose up to the mounted plate and secure using provided screws.

Note: Ensure that the weight of the pendant is fully supported during the electrical installation.

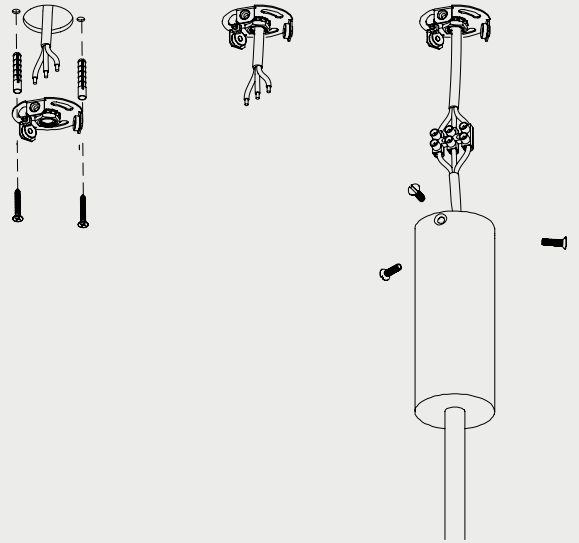

- 3.** 120v
US Fix the US adaptor plate to the junction box using suitable screws (not supplied).

Attach the US cover plate on the US adaptor plate.

Raise the pendant and make the electrical connections inside the ceiling rose cover ensuring all wires are colour matched and the pendant is earthed correctly.

Bring the ceiling rose up to the mounted plate and secure using provided screws.

Note: Ensure that the weight of the pendant is fully supported during the electrical installation.

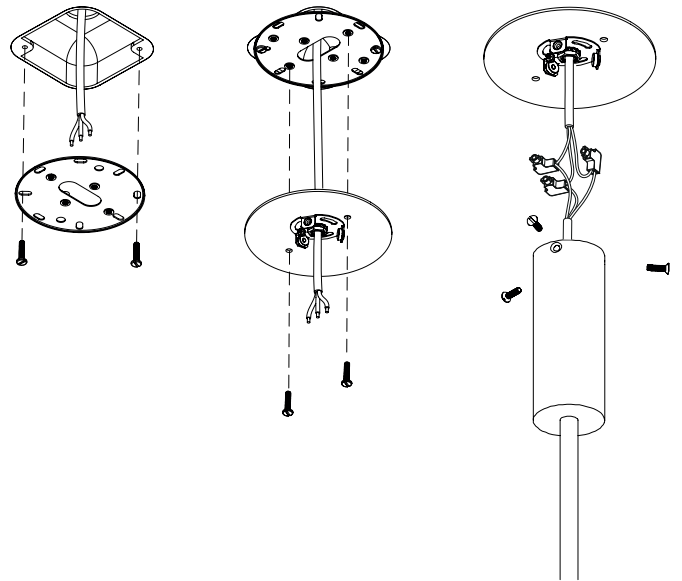

MAINTENANCE

Cleaning

Dust using a dry lint-free cloth weekly or as required

Repairs

Contact
CTO Lighting

Warranty

Please visit
[www.ctolighting.co.uk/
pages/f-a-q](http://www.ctolighting.co.uk/pages/f-a-q)
for CTO warranty policy

Certification

