

A-3571

493035712

Metallic wall light with a vertically mounted tube providing indirect light and one adjustable reading arm providing direct light. Independent on/off switch on the backplate.

Aplique metálico con un brazo vertical que proporciona luz indirecta y un brazo de lectura ajustable que proporciona luz directa. Interruptores independientes en la placa posterior.

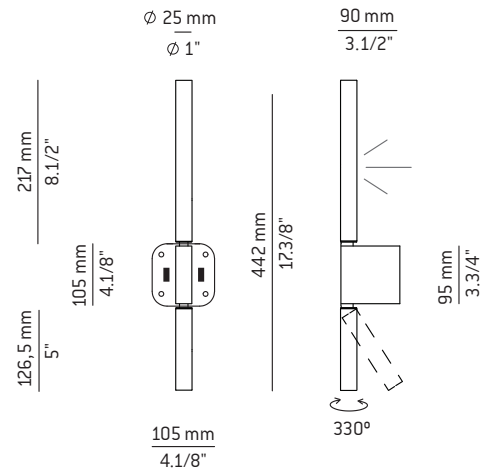

Warning

PRODUCT IS TO BE INSTALLED BY A QUALIFIED ELECTRICIAN ONLY
LE PRODUIT DOIT ÊTRE INSTALLÉ PAR UN ÉLECTRICIEN QUALIFIÉ UNIQUEMENT
EL PRODUCTO DEBE SER INSTALADO SOLO POR UN ELECTRICISTA CUALIFICADO

WE RECOMMEND TO READ THE INSTRUCTIONS ENTIRELY BEFORE BEGINNING THE INSTALLATION
PLEASE SAVE THE INSTRUCTIONS FOR FUTURE REFERENCE

- * Make sure the power has been disconnected before installing the fixture.
- * Lighting fixtures should be installed only by qualified personnel.
- * For indoor use only.
- * Do not use alcohol or solvents to clean the lamp
- * For your convenience, assembly by two people is recommended.

The light source of this luminaire is not replaceable.
Once the light source's lifecycle ends, you may contact the manufacturer.

LE RECOMENDAMOS LEA LAS INSTRUCCIONES ANTES DE PROCEDER A LA INSTALACIÓN
GUARDE LAS INSTRUCCIONES PARA FUTURAS REFERENCIAS

- * Asegúrese de que la corriente está desconectada antes de conectar el aparato.
- * El montaje de luminarias debe ser efectuado solamente por personal técnico.
- * Únicamente para uso en interiores.
- * Para limpieza no utilizar alcohol ni disolventes
- * Recomendamos la intervención de 2 personas para el montaje de la lámpara.

La fuente de luz de esta luminaria no es reemplazable. Cuando la fuente de luz alcance el final de su vida, debe ponerse en contacto con el fabricante para su reparación.



UL 1598 ELECTRICAL INSTRUCTIONS FOR FLUSHMOUNTS, WALL SCONCES AND PENDANTS

SAVE THESE INSTRUCTIONS. MIN 90C SUPPLY CONDUCTORS. CAUTION-RISK OF FIRE. USE STATED WATT OR SMALLER. CAUTION-RISK OF SHOCK. DISCONNECT POWER BEFORE SERVICING. TO REDUCE THE RISK OF A BURN DURING RELAMPING, ALLOW THE BULB TO COOL DOWN. SUITABLE FOR DAMP LOCATION. THIS PRODUCT MUST BE INSTALLED IN ACCORDANCE WITH THE APPLICABLE INSTALLATION CODE BY A PERSON FAMILIAR WITH THE CONSTRUCTION AND OPERATION OF THE PRODUCT AND THE HAZARD INVOLVED.

WARNING: ALL WIRES AND WIRE NUTS USED IN THE INSTALLATION MUST BE RATED 195F (90°C). FOR INDOOR USE ONLY. THESE PRODUCT MUST BE INSTALLED BY A QUALIFIED ELECTRICIAN.

Assembly instructions / Instrucciones

- 1 - Connect the electrical cables coming from the lamp and the switch (A) inside the junction box (B).
Attention: make sure you match the color of the wires.
Figure 1.

- 1 - Conectar los cables procedentes de la lámpara y el pulsador (A) con los cables de la caja de conexiones (B).
Atención: todos los cables blancos juntos y todos los cables negros juntos.
Figura 1.

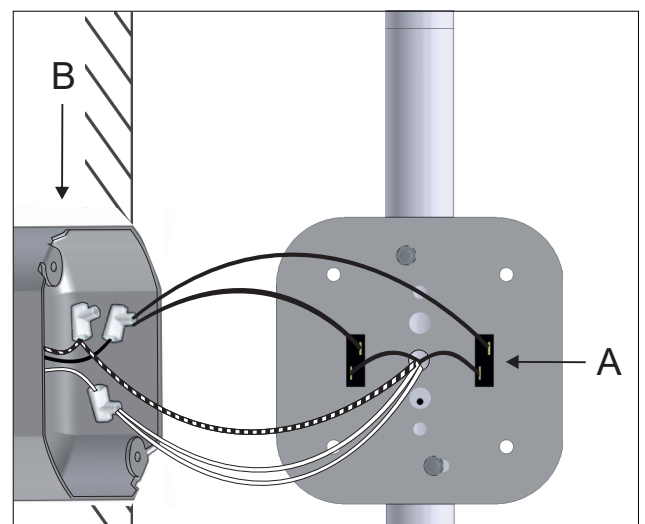

Figure 1

2 - Keep in mind that the connection box only has two points to hold the lamp (C), and the mounting bracket has four. This allows the fixture to be installed horizontally or vertically regardless of the orientation of the box. Figure 2

2 - Observar que la caja de conexiones sólo tiene dos puntos para sujetar la lámpara (C), y la sujeción tiene cuatro agujeros. En función de la posición de la luminaria, decidir que agujeros sujetarán el cuerpo de la lámpara y que agujeros quedaran libres. Figura 2.

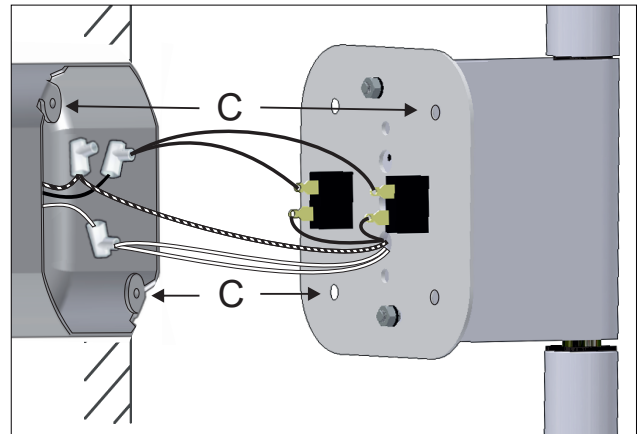

Figure 2

3 - Thread the decorative screw (D) into the holes that are not used to hold the lamp before installing the mounting bracket to the wall.
Attention: put the washer (E) on the screw and tighten the nut. Figure 3

3 - Roscar el tornillo decorativo (D) en los agujeros que no se utilizan para sujetar la lámpara. A continuación fijar la sujeción a la caja de conexiones.
Atención: poner la arandela (E) para asegurarse de dejarla bien apretada. Figura 3.

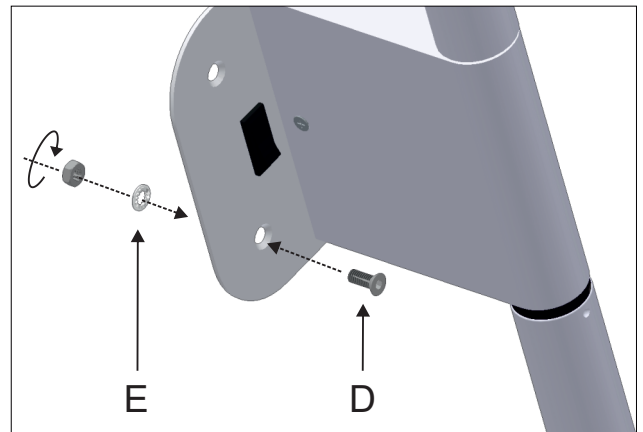

Figure 3

4 - You can pull and rotate to place the arm in the right position. Figure 4.

4 - Tirar y rotar para mantener fija la posición del brazo de lectura Figura 4.

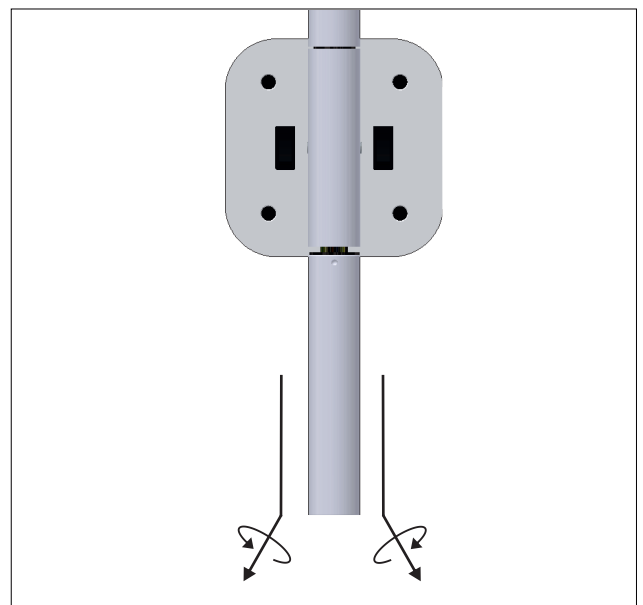

Figure 4