

Atlantis, a Precious Wave.







design Barlas Baylar
terzani.com



Type |
Suspension

Materials |
Brass chains and metal structure plated as below

Finishes | Code

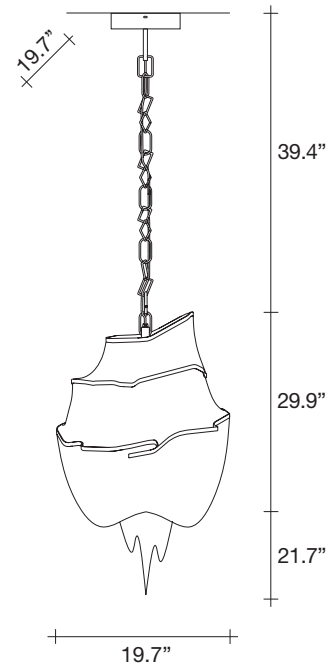

-  Nickel
0A13S E7 C8
-  Black Nickel
0A13S E9 C8
-  Bronze
0A13S F7 C8
-  Gold
0A13S L6 C8
-  Champagne
0A13S N1 C8
-  Brushed champagne
0A13S N7 C8

Body |



Recommended Light | Canopy |

120V ~ 50/60Hz

-  LED
6 x 5.5W E12
-  Dimmable with
all systems

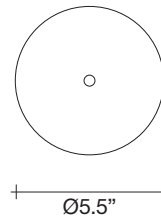

Seemingly alive, atlantis' shimmering light creates a vibrant source of energy. Its mesmerizing, organic effect is created by hundreds of illuminated lengths of draped, nickel chain. Like water in the ocean, atlantis' chains appear liquid, cascading over its gloss nickel bands and falling down towards the abyss before turning back into itself. Atlantis is composed of almost three miles of chain, meticulously hand-crafted by master italian artisans. Design Barlas Baylar.

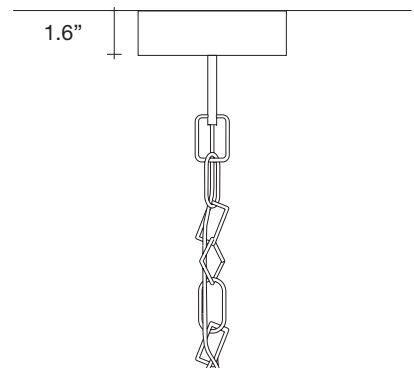

119



39.7



29.5" x 29.5" x 45.3"

Atlantis, a Precious Wave.







design Barlas Baylar
terzani.com



Type |
Suspension

Materials |
Brass chains and metal structure plated as below

Finishes | Code

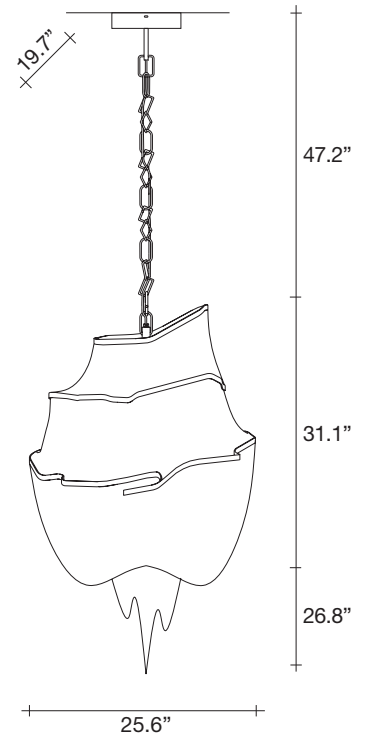

-  Nickel
0A14S E7 C8
-  Black Nickel
0A14S E9 C8
-  Bronze
0A14S F7 C8
-  Gold
0A14S L6 C8
-  Champagne
0A14S N1 C8
-  Brushed champagne
0A14S N7 C8

Body |



Recommended Light | Canopy |

120V ~ 50/60Hz

-  LED
8 x 5.5W E12
-  Dimmable with all systems

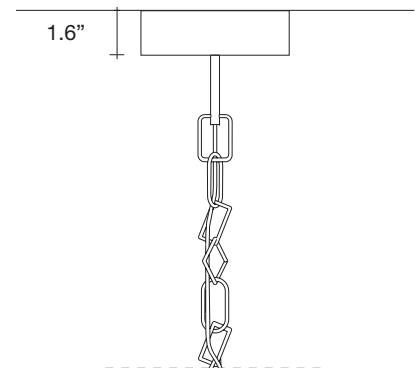
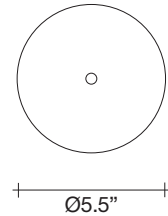

Seemingly alive, atlantis' shimmering light creates a vibrant source of energy. Its mesmerizing, organic effect is created by hundreds of illuminated lengths of draped, nickel chain. Like water in the ocean, atlantis' chains appear liquid, cascading over its gloss nickel bands and falling down towards the abyss before turning back into itself. Atlantis is composed of almost three miles of chain, meticulously hand-crafted by master italian artisans. Design Barlas Baylar.



128



62



35.4" x 29.5" x 51.6"

Atlantis, a Precious Wave.







design Barlas Baylar
terzani.com



Type |
Suspension

Materials |
Brass chains and metal structure plated as below

Finishes | Code

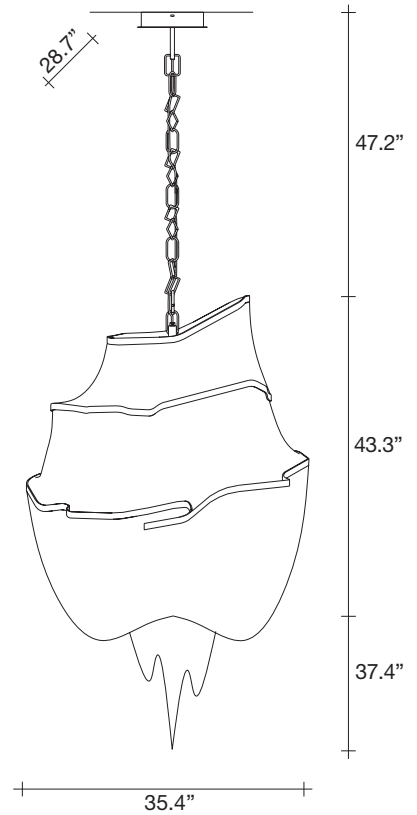

-  Nickel
0A15S E7 C8
-  Black Nickel
0A15S E9 C8
-  Bronze
0A15S F7 C8
-  Gold
0A15S L6 C8
-  Champagne
0A15S N1 C8
-  Brushed champagne
0A15S N7 C8

Body |



Recommended Light | Canopy |

120V ~ 50/60Hz

-  LED
8 x 5.5W E12
-  Dimmable with all systems

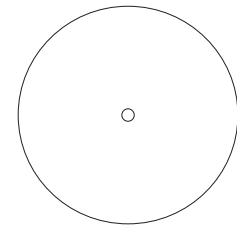

Ø8.7"

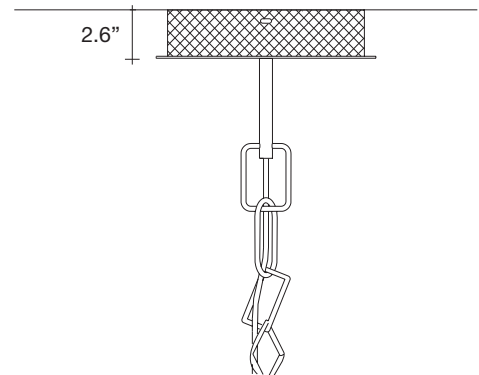

Seemingly alive, atlantis' shimmering light creates a vibrant source of energy. Its mesmerizing, organic effect is created by hundreds of illuminated lengths of draped, nickel chain. Like water in the ocean, atlantis' chains appear liquid, cascading over its gloss nickel bands and falling down towards the abyss before turning back into itself. Atlantis is composed of almost three miles of chain, meticulously hand-crafted by master italian artisans. Design Barlas Baylar.



201



82



45.3" x 33.4" x 59.1"

Atlantis, a Precious Wave.







design Barlas Baylar
terzani.com



Type |
Suspension

Materials |
Brass chains and metal structure plated as below

Finishes | Code

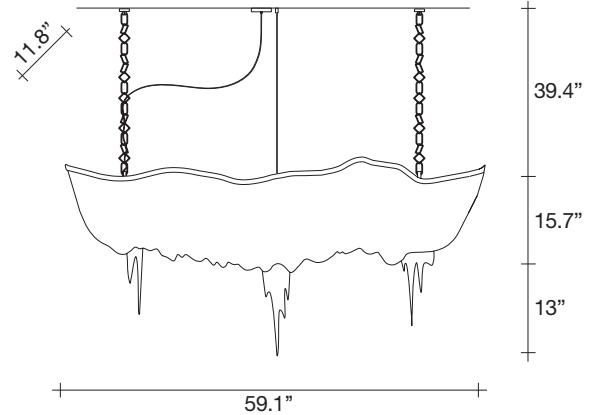

-  Nickel
0A18S E7 C8
-  Black Nickel
0A18S E9 C8
-  Bronze
0A18S F7 C8
-  Gold
0A18S L6 C8
-  Champagne
0A18S N1 C8
-  Brushed champagne
0A18S N7 C8

Body |



Recommended Light | Canopy |

120V ~ 50/60Hz

-  LED
8 x 5.5W E12
-  Dimmable with
all systems

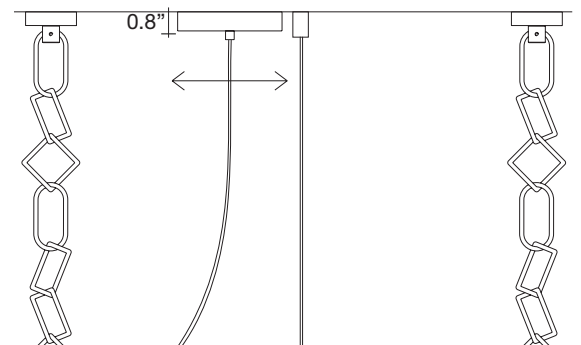
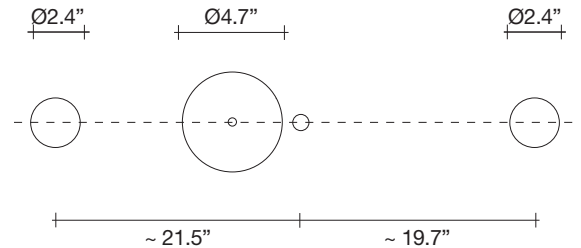

Seemingly alive, atlantis' shimmering light creates a vibrant source of energy. Its mesmerizing, organic effect is created by hundreds of illuminated lengths of draped, nickel chain. Like water in the ocean, atlantis' chains appear liquid, cascading over its gloss nickel bands and falling down towards the abyss before turning back into itself. Atlantis is composed of almost three miles of chain, meticulously hand-crafted by master italian artisans. Design Barlas Baylar.



 155  75  60.8" x 23.6" x 39.8"

Atlantis, a Precious Wave.







design Barlas Baylar
terzani.com



Type |
Suspension

Materials |
Brass chains and metal structure plated as below

Finishes | Code

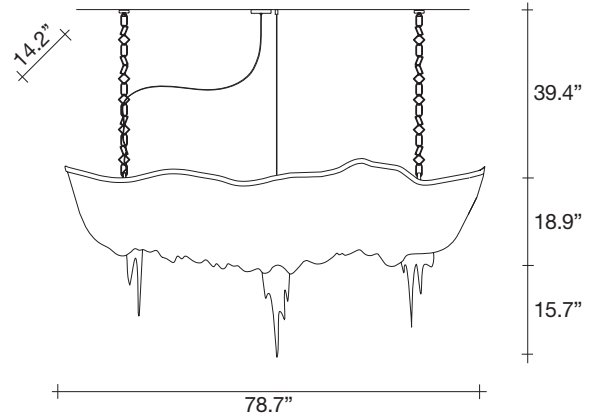

-  Nickel
0A17S E7 C8
-  Black Nickel
0A17S E9 C8
-  Bronze
0A17S F7 C8
-  Gold
0A17S L6 C8
-  Champagne
0A17S N1 C8
-  Brushed champagne
0A17S N7 C8

Body |



Recommended Light | Canopy |

120V ~ 50/60Hz

-  LED
10 x 5.5W E12
-  Dimmable with all systems

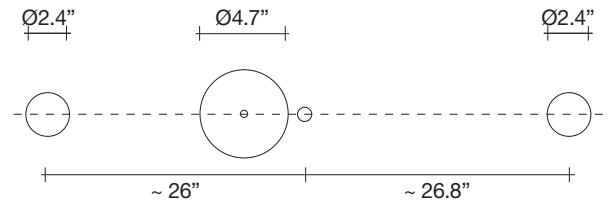

Seemingly alive, atlantis' shimmering light creates a vibrant source of energy. Its mesmerizing, organic effect is created by hundreds of illuminated lengths of draped, nickel chain. Like water in the ocean, atlantis' chains appear liquid, cascading over its gloss nickel bands and falling down towards the abyss before turning back into itself. Atlantis is composed of almost three miles of chain, meticulously hand-crafted by master italian artisans. Design Barlas Baylar.

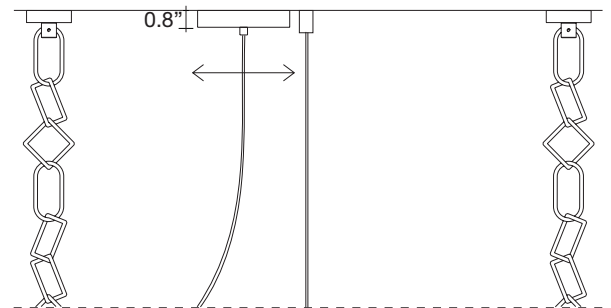

216



90.4



86.6" x 27.6" x 41.7"

Atlantis, a Precious Wave.







design Barlas Baylar
terzani.com



Type |
Suspension

Materials |
Brass chains and metal structure plated as below

Finishes | Code

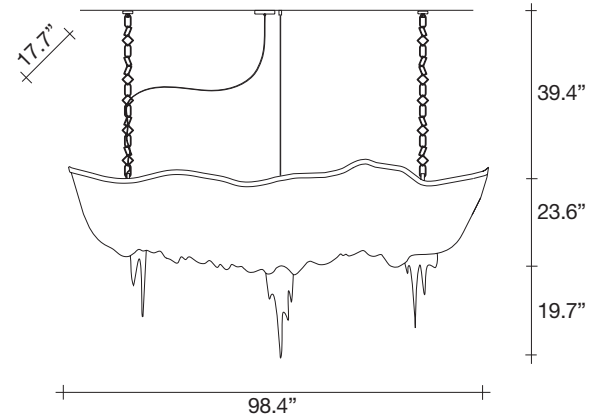

-  Nickel
0A16S E7 C8
-  Black Nickel
0A16S E9 C8
-  Bronze
0A16S F7 C8
-  Gold
0A16S L6 C8
-  Champagne
0A16S N1 C8
-  Brushed champagne
0A16S N7 C8

Body |



Recommended Light | Canopy |

120V ~ 50/60Hz

-  LED
10 x 5.5W E12
-  Dimmable with
all systems

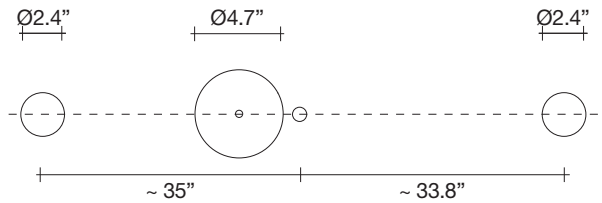

Seemingly alive, atlantis' shimmering light creates a vibrant source of energy. Its mesmerizing, organic effect is created by hundreds of illuminated lengths of draped, nickel chain. Like water in the ocean, atlantis' chains appear liquid, cascading over its gloss nickel bands and falling down towards the abyss before turning back into itself. Atlantis is composed of almost three miles of chain, meticulously hand-crafted by master italian artisans. Design Barlas Baylar.

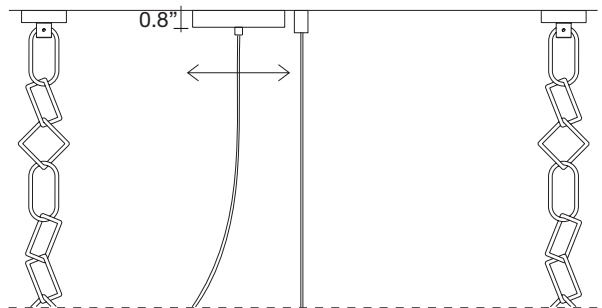

 322  146  108.3" x 29.5" x 45.7"

Atlantis, a Precious Wave.

design Barlas Baylar
terzani.com



Type |
Suspension

Materials |
Brass chains and metal structure plated as below

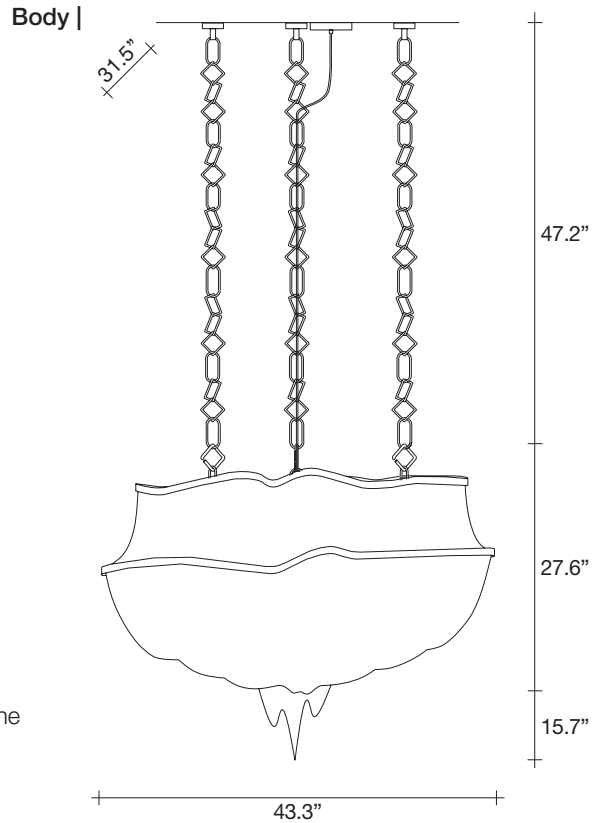

Finishes | Code

-  Nickel
OJ01S E7 C8
-  Black Nickel
OJ01S E9 C8
-  Bronze
OJ01S F7 C8
-  Gold
OJ01S L6 C8
-  Champagne
OJ01S N1 C8
-  Brushed champagne
OJ01S N7 C8



Recommended Light | Canopy |

120V ~ 50/60Hz

-  LED
10 x 5.5W E12
-  Dimmable with
all systems

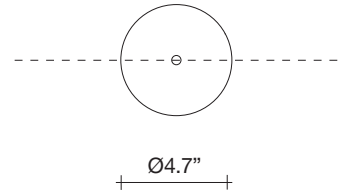

Seemingly alive, atlantis' shimmering light creates a vibrant source of energy. Its mesmerizing, organic effect is created by hundreds of illuminated lengths of draped, nickel chain. Like water in the ocean, atlantis' chains appear liquid, cascading over its gloss nickel bands and falling down towards the abyss before turning back into itself. Atlantis is composed of almost three miles of chain, meticulously hand-crafted by master italian artisans. Design Barlas Baylar.

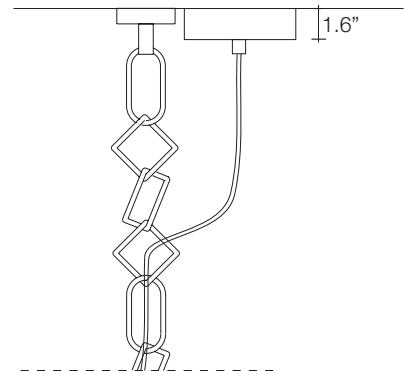

203



99.2



53.2" x 39.4" x 43.3"

Atlantis, a Precious Wave.

design Barlas Baylar
terzani.com



Body |

Type |
Suspension

Materials |
Brass chains and metal structure plated as below

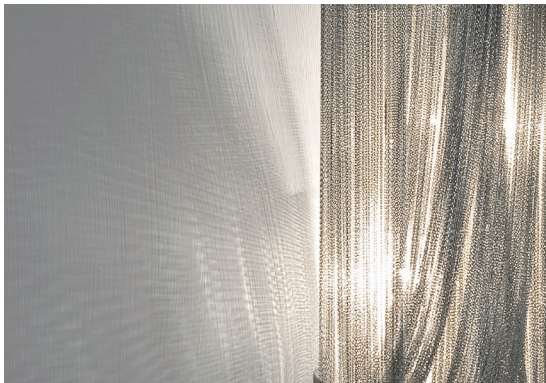
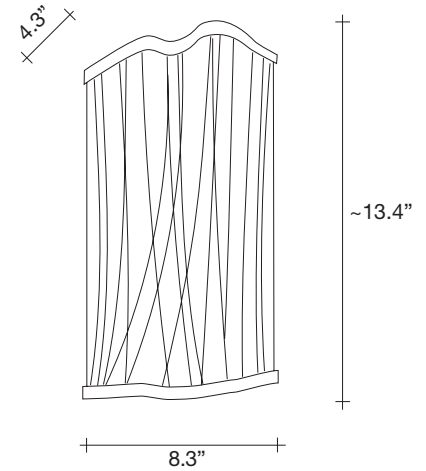

Finishes | Code

-  Nickel
OJ04A E7 C8
-  Black Nickel
OJ04A E9 C8
-  Bronze
OJ04A F7 C8
-  Gold
OJ04A L6 C8
-  Champagne
OJ04A N1 C8
-  Brushed champagne
OJ04A N7 C8



Recommended Light | Canopy |

120V ~ 50/60Hz

-  LED
2 x 5.5W E12
-  Dimmable with
all systems

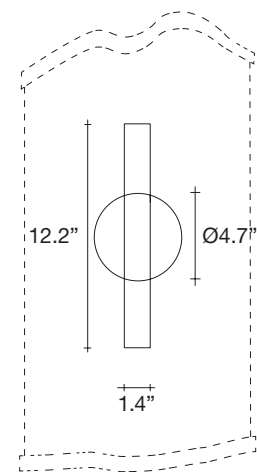

Seemingly alive, atlantis' shimmering light creates a vibrant source of energy. Its mesmerizing, organic effect is created by hundreds of illuminated lengths of draped, nickel chain. Like water in the ocean, atlantis' chains appear liquid, cascading over its gloss nickel bands and falling down towards the abyss before turning back into itself. Atlantis is composed of almost three miles of chain, meticulously hand-crafted by master italian artisans. Design Barlas Baylar.

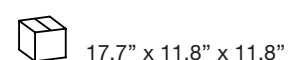

Atlantis, a Precious Wave.

design Barlas Baylar
terzani.com



Type |
Suspension

Materials |
Brass chains and metal structure plated as below

Finishes | Code

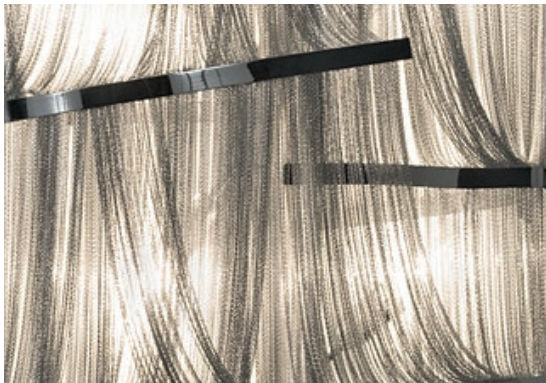
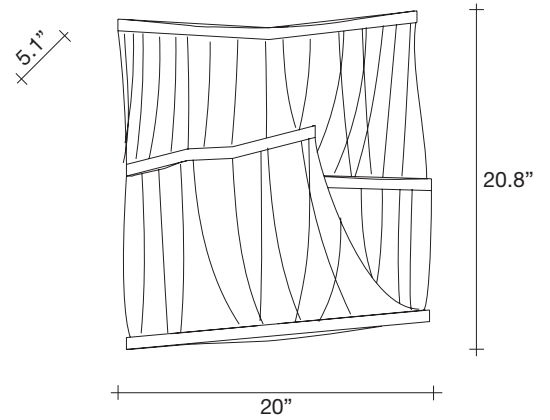

-  Nickel
OJ03A E7 C8
-  Black Nickel
OJ03A E9 C8
-  Bronze
OJ03A F7 C8
-  Gold
OJ03A L6 C8
-  Champagne
OJ03A N1 C8
-  Brushed champagne
OJ03A N7 C8

Body |



Recommended Light | Canopy |

120V ~ 50/60Hz

-  LED
4 x 5.5W E12
-  Dimmable with all systems

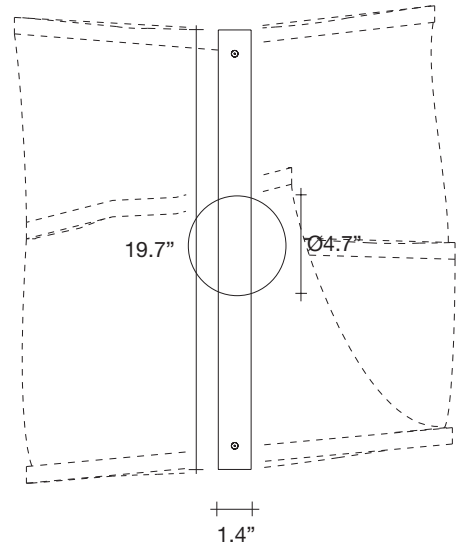

Seemingly alive, atlantis' shimmering light creates a vibrant source of energy. Its mesmerizing, organic effect is created by hundreds of illuminated lengths of draped, nickel chain. Like water in the ocean, atlantis' chains appear liquid, cascading over its gloss nickel bands and falling down towards the abyss before turning back into itself. Atlantis is composed of almost three miles of chain, meticulously hand-crafted by master italian artisans. Design Barlas Baylar.



19.8



13.2



26.4" x 26.4" x 9.1"

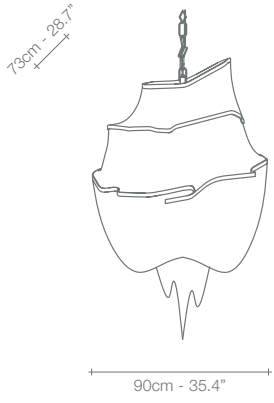

A15S

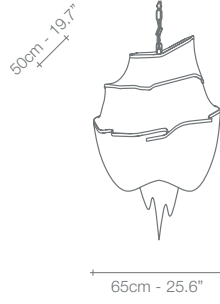

A14S

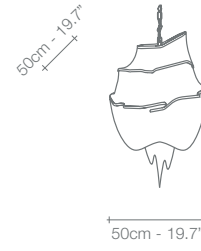

A13S

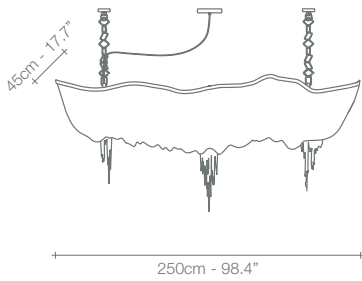

A16S

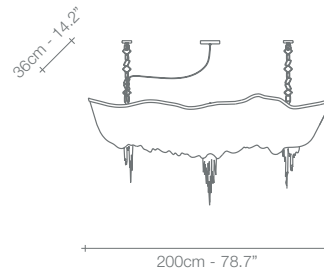

A17S

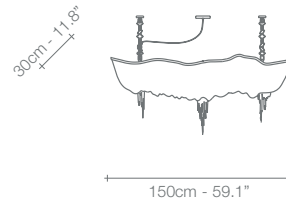

A18S

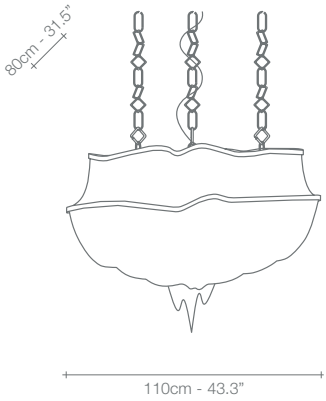

J01S

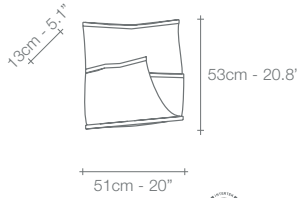

J03A

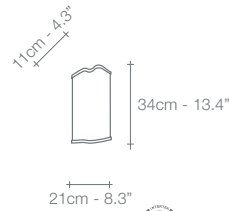

J04A



NICKEL



BLACK NICKEL

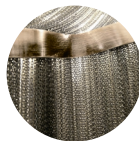

BRONZE



GOLD

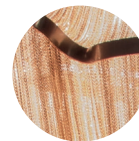

CHAMPAGNE

RECOMMENDED BULB A13S A14S A15S A16S A17S A18S J01S J03A J04A

230V **E14 LED** | 6x6W 8x6W 8x6W 10x6W 10x6W 8x6W 10x6W 4x6W 2x6W

Dimmable with all systems |

120V **E12 LED** | 6x5.5W 8x5.5W 8x5.5W 10x5.5W 10x5.5W 8x5.5W 10x5.5W 4x5.5W 2x5.5W

Dimmable with all systems |