

General Product information

This product is suitable for indoor dry locations only.

This product can be dimmed with most standard dimmers. Please see "Dimmer Compatibility" section of these instructions for more information.

CAUTION - RISK OF FIRE

This product requires installation by a qualified electrician. Before installing be sure to read all instructions and **TURN POWER OFF TO THE JUNCTION BOX**

Adjusting the Fixture Height

- 1 Measure the desired height (H) that you want the fixture to hang below the ceiling.
- 2 Thread the cables through the canopy fasteners, canopy, crossbars, and washers.
- 3 Tie a knot in the cable at the desired length H

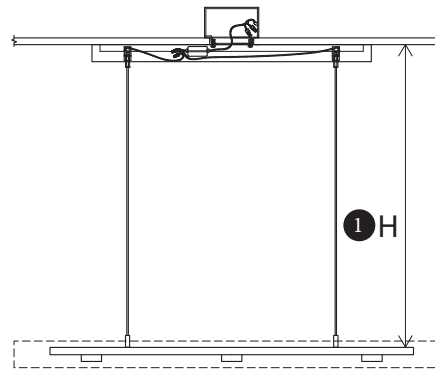

Figure 1

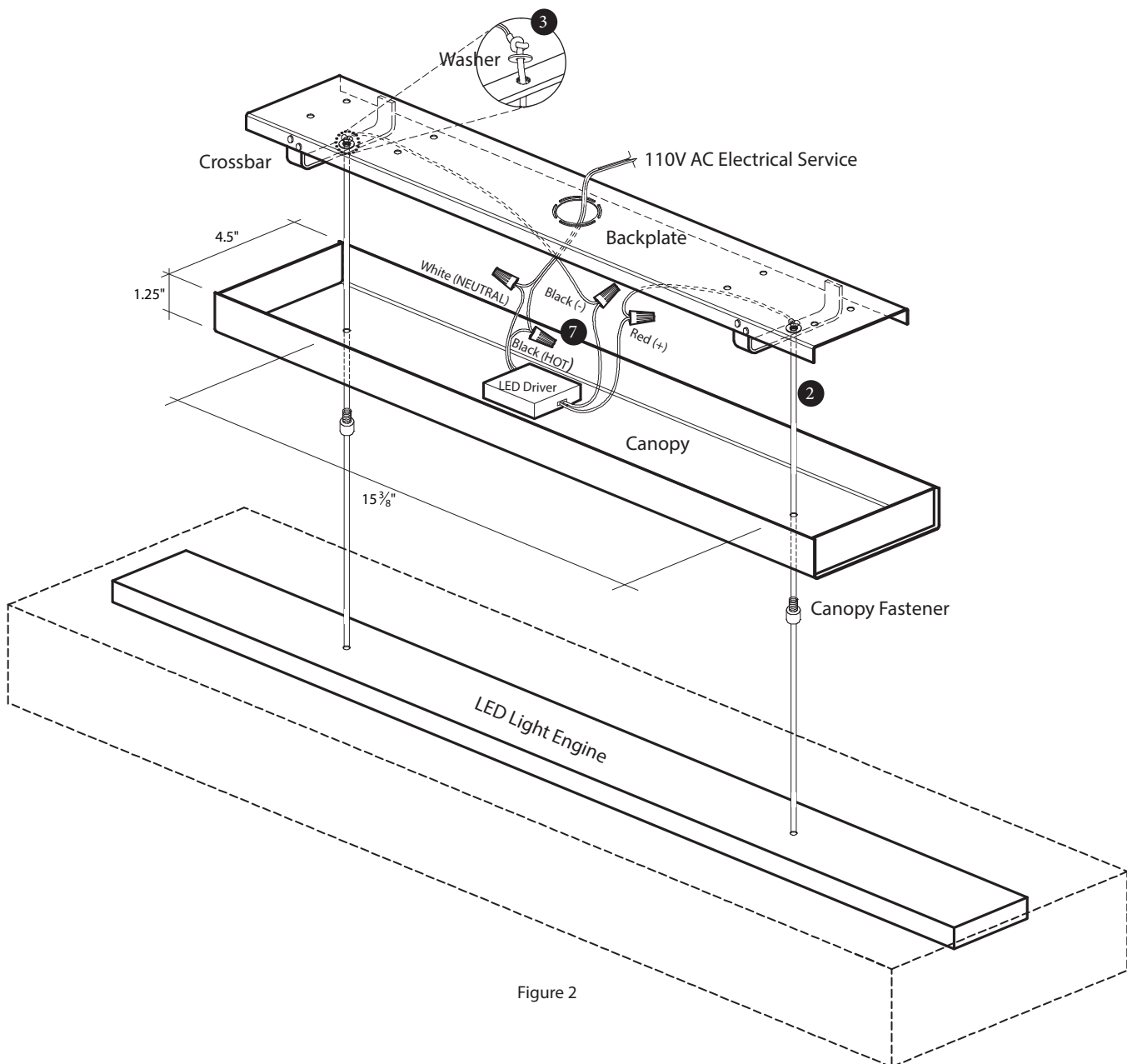

Figure 2

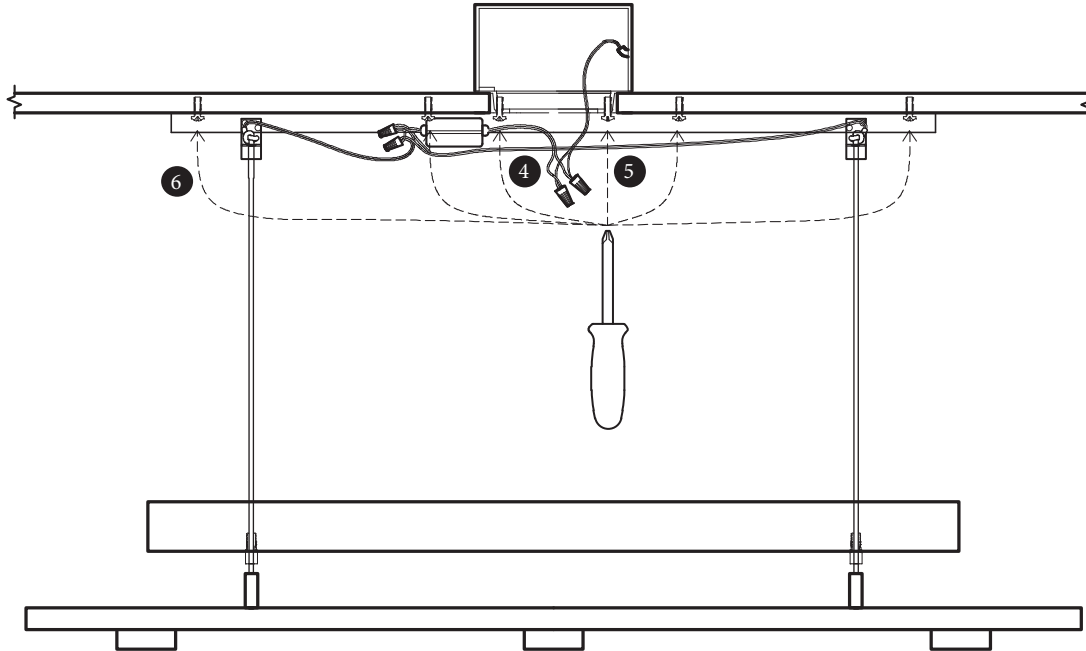

Figure 3

Mounting the Fixture

- 4 Feed the power line wires through the hole in the center of the backplate.
- 5 Mount the backplate to the electrical box with the supplied #8-32 screws.
- 6 Secure the backplate to the ceiling using the additional mounting holes.

Making Electrical Connections

- 7 Make electrical connections as shown in figure 2 using the supplied wire nuts.

WARNING - THE LED DRIVER IS A DC DEVICE AND MUST BE ATTACHED TO THE LED LIGHT ENGINE AS SHOWN. CONNECTING THIS DEVICE INCORRECTLY WILL CAUSE SEVERE DAMAGE.

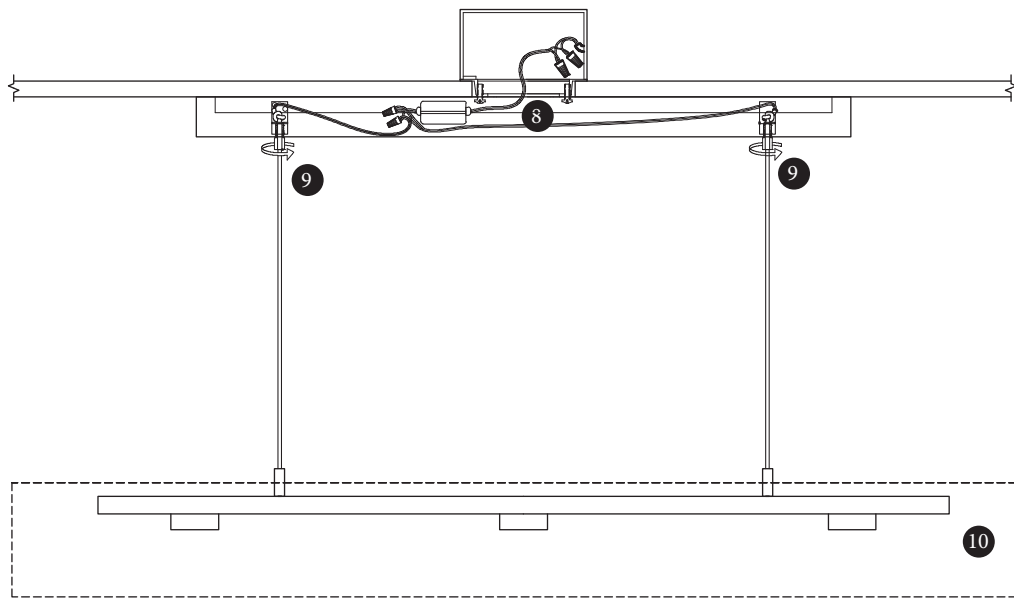
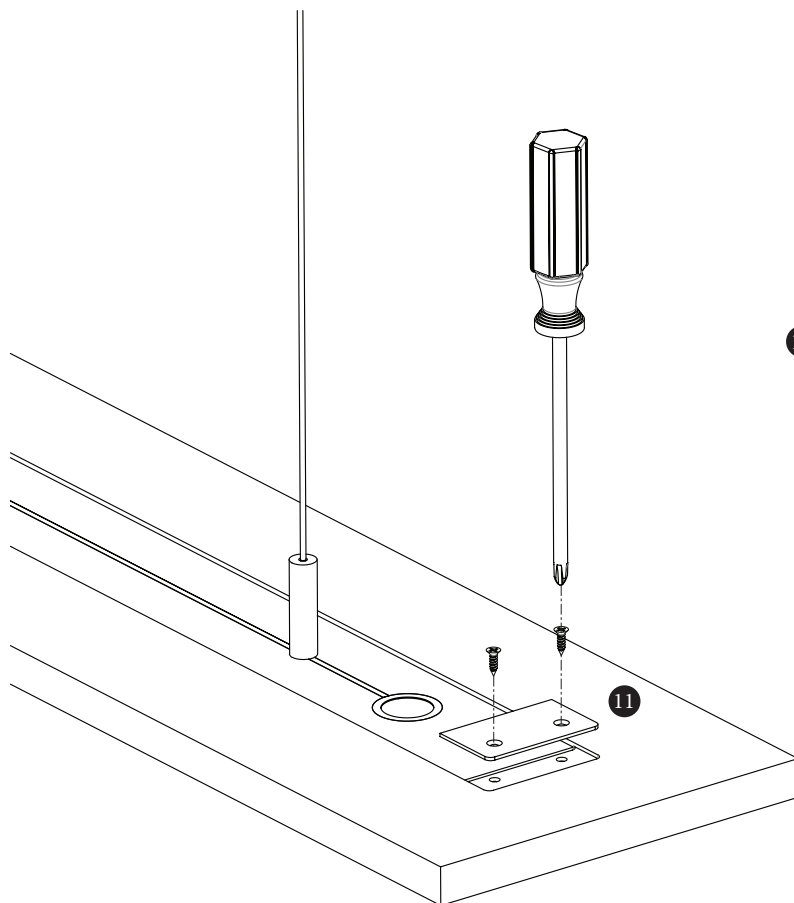

Figure 4

Securing the Canopy

- 8 After electrical connections have been made, place all of the wires inside of the junction box.
- 9 Slide the canopy up the cables and secure it by screwing the canopy fasteners into the crossbars.
- 10 Install the shade



Removing / Attaching shade to Vix light engine

- 11 Screw tab into shade securing light engine. (center tab only on Vix 48")

Dimmer Compatibility

The LED driver included with this fixture is designed to operate with most standard dimmers. Extensive testing with the dimmers listed below has been conducted. This list of dimmers does not imply any guarantee or warranty of compatibility with a particular application. The lack of dimmers on this list does not imply it is not compatible. All power ratings and installation instructions from dimmer manufacturers' instruction sheets must be followed.

Cooper, Aspire Series (Part numbers 9530XXX)
Leviton, Illumitech Series (Part numbers IPI06-XXX)
Leviton, Trimatron Series (Part numbers 6602-X, 6681-X, 6683-X, 6684-X, 700-X and 705-X)
Leviton, SureSlide Series (Part Numbers 6631)
Leviton, True Touch Series (Part Number 6606-1LM)
Lutron Skylark Series (Part Number S-600, S2-LH)

In addition, the following Electronic Low Voltage (ELV) dimmers that employ reverse phase control have been tested:

Lutron Maestro (Part Number MAELV-600)
Lutron Nova T Series (Part Number NTELV-600)
Lutron Faedra (Part Number FAELV-500-XX)
Leviton Acenti (Part Number ACE06-XXX)
Leviton Vizia (Part Number VZE04)

Care, maintenance instructions

Regularly maintaining your Cerno® product is easy and will help keep it looking beautiful. Scratches can be buffed out in minutes. Wood surfaces will be revitalized with minimal effort every few years. The LED light source is rated to last 50,000 hours, and should last the life of the product. Your linear pendant may include materials listed below. Please use these tips to keep your product looking its best.

Oiled Walnut: Wood surfaces should be dusted and cleaned with a damp cloth. Every 1 - 3 years, re-oil and wax wood surfaces to maintain the rich wood sheen. Remember to wipe with the wood grain, and remove any excess oil or wax when finished.

Dark Stained Walnut: Wood surfaces should be dusted and cleaned with a damp cloth. Wax every 1 - 3 years, taking care to wipe with the grain. Remove any excess wax when finished.

Brushed Aluminum: Everyday cleaning of metal surfaces can be done with a damp cloth. Repair: To remove scratches from brushed aluminum, use Scotch-Brite (Gray or Maroon) to buff the scratched area. In a pinch, you can use the rough side of your kitchen sponge.

Black Anodized Aluminum: Everyday cleaning of metal surfaces can be done with a damp cloth.

Cerno's mission since the company's inception has been to fuse quality, performance and resource efficiency with contemporary design.

Producing environmentally responsible products involves far more details than merely guaranteeing your products energy efficient performance and maintaining eco conscious manufacturing practices. We live in a consumer age characterized by excess and waste, where nearly everything we possess is viewed as disposable, from the cars we drive to the bottle of water you are drinking right now.

At Cerno we aim to provide our customers an opportunity to purchase objects of value to enhance their built environment. We construct our products with integrity that will pass the test of time with the goal of evading a premature trip to the local landfill. All the products are assembled by human hands and endure rigorous testing to assure that our exceptionally high standards of quality are always satisfied.

Warranty

In addition to our two year product defect warranty, Cerno offers a repair service for the life of your product. Every Cerno product is designed and manufactured in the United States which facilitates excellent quality control and easy access to our engineers and service technicians. At Cerno we pride ourselves on delivering products executed with an unparalleled level of craftsmanship. For any reason should our customers have an issue with their orders upon delivery we will repair or replace the item.

In addition to our warranty and quality guarantees, Cerno welcomes customer feedback so please e-mail all comments to info@cernogroup.com