

# PINECONE

Paola Navone, 2016

Pinecone is a pendant and table lamp mounting a blown glass diffuser, available in the glossy transparent or milky white acid-etched version. The diffuser is manufactured using the ancient caged blown glass technique: the glass maker blows the molten glass blob into a metal cage, which only partly contains the blob's natural expansion. In this way, the glass surface is partly trapped by and partly escapes the cage, generating an impression of tension as the object struggles to free itself from its harness; the cage is further enriched by the galvanic treatment that makes it look polished and brilliant. The transparent version, in particular, reveals a two-fold structure that multiplies the scenic effect, while the metal cage pattern projects kaleidoscopic shade effects on the surrounding surfaces. On the contrary, in the white version the glass delicately envelops the cage surface and enhances its geometric pattern, generating an elegant and visually pleasing diffuse light. Illuminated by a light source that can be chosen by the user, the lighting fixture makes a highly appealing and striking impact either switched on or off.

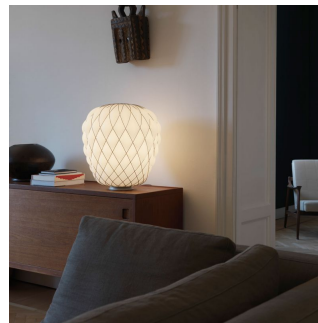

## RELATED PRODUCTS

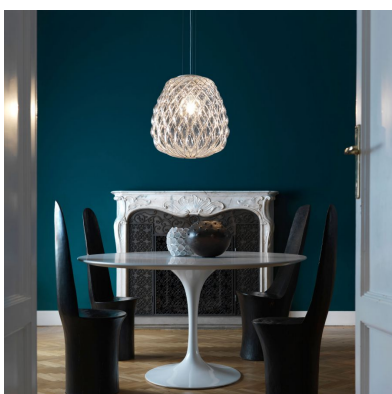

## PINECONE

*Suspension Lamp*

## TECHNICAL SHEET

Table lamp. Diffuser in transparent or milky acid-etched blown glass. Nickel-plated metal cage. White metal base. Transparent dimmer, plug and power cord.

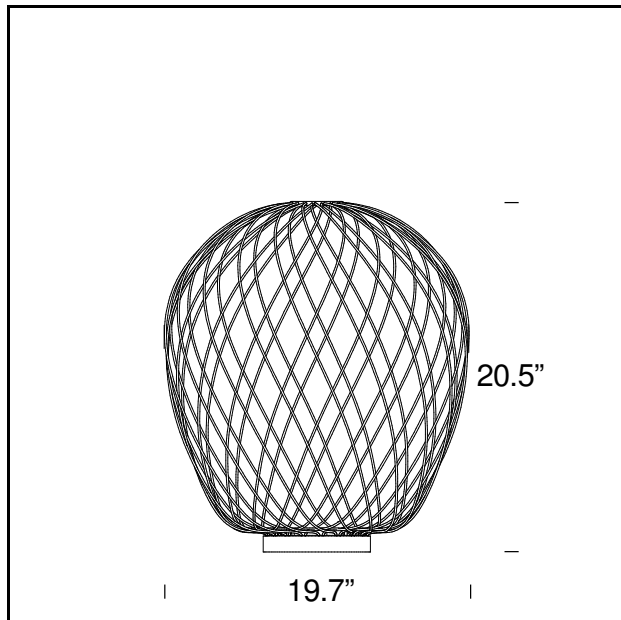

**MODEL NAME:** Pinecone

**CODE:** UL4340..

**DIMENSION:**  $\varnothing$  19.7"  $\times$  20.5"

**MATERIALS:** Glass, metal

### COLORS

- Chrome/Transparent
- Chrome/White
- Gold/Transparent
- Gold/White

**LIGHTING SOURCE:** 1 $\times$ 150W (HA/FL/LED) E26

### CERTIFICATIONS AND SYMBOLS:



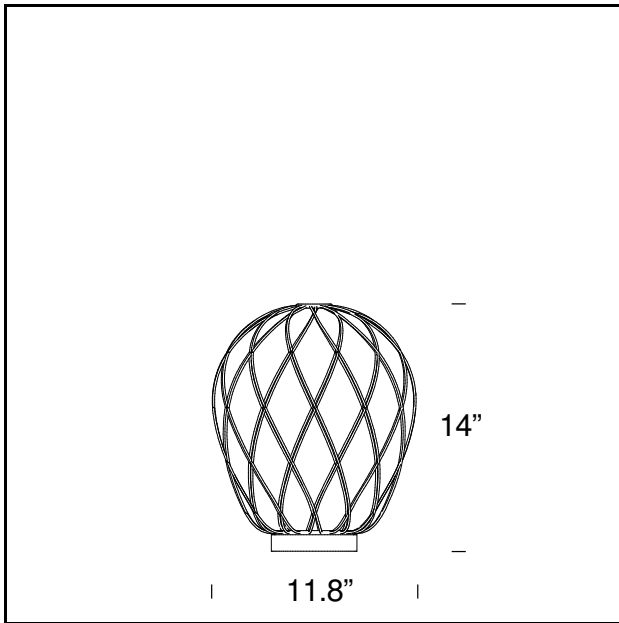

**MODEL NAME:** Pinecone

**CODE:** UL4364..

**DIMENSION:**  $\varnothing$  11.8"  $\times$  14"

**MATERIALS:** Glass, metal

### COLORS

☉ Chrome/Transparent

☉ Chrome/White

☉ Gold/Transparent

☉ Gold/White

**LIGHTING SOURCE:** 1 $\times$ 116W (HA, FL, LED) E26

Subject to technical modifications and modifications to content